



## **AURATON Aquila SET**

User manual ver. 20200829

The document presents collected information on safety, assembly and use of AURATON Aquila SET.

---

### **Daily wireless temperature regulator with heating device controller Auraton Fornax (set)**

AURATON Aquila SET is a set of a daily wireless temperature regulator with a controller of the AURATON Fornax heating device, designed to work with a gas or electric heating device.



#### **FrostGuard function**

to protect against freezing of the room.



Possibility of cyclic lowering the programmed temperature by 3 °C for a period of 6 hours.

#### **LCD**

#### **Backlit LCD display**

The backlit display makes it possible to monitor the device's operation even in poorly lit rooms.

## **Description AURATON Aquila R**

## 24-Hour Wireless Thermostat (transmitter)

On the front panel of AURATON Aquila R, there is a backlit LCD display and three function buttons.

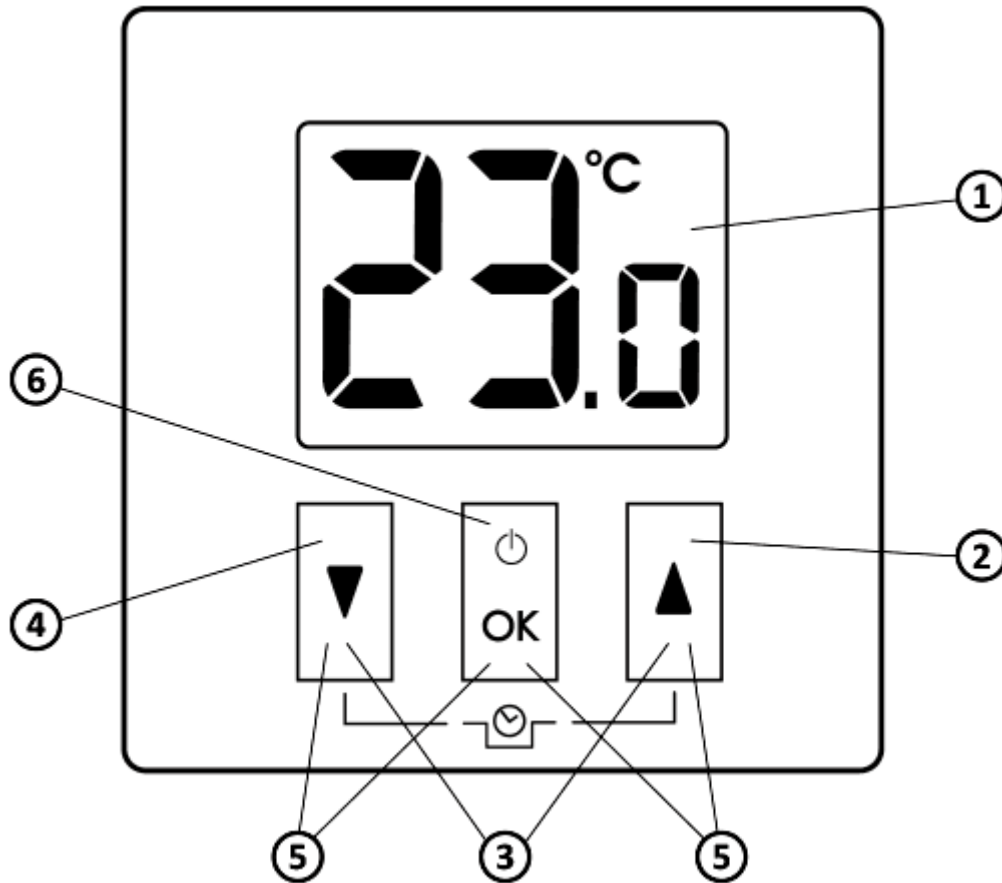

1. LCD display
2. Temperature increase button
3. Temporary temperature reduction mode buttons
4. Temperature decrease button
5. Pairing buttons
6. Approval or on/off button. AURATON Aquila R

• **hold** - on/off AURATON Aquila R (🔌)



• **short pressing** - confirms the temperature setting (OK)

## Display

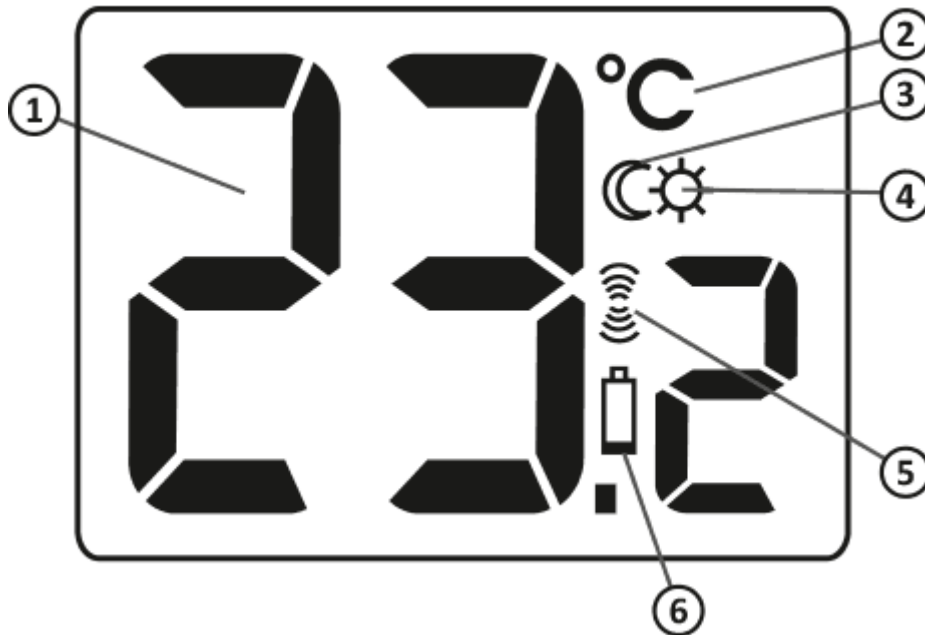

### 1. **Temperature**

In normal operation mode, AURATON Aquila R displays the temperature of the room in which it is installed.

### 2. **Temperature unit (°C)**

Indicates that the temperature is displayed in degrees Celsius.

### 3. **Temporary temperature lowering mode indicator (C)**

Active during a temperature cutback timer program.

### 4. **Temporary temperature lowering mode programming indicator (☀)**

It indicates that the user has enabled temporary temperature lowering mode. Visible when the mode is not in effect, but the temporary temperature lowering function is active (*for more information see the chapter "Setting the temporary temperature lowering mode"*).

### 5. **Transmission symbol (📶)**

It indicates communication with the receiver.

### 6. **Battery depletion (🔋)**

Indicator visible when the minimum acceptable battery voltage is exceeded. Replace the batteries as soon as possible.

## Choosing the right location for AURATON Aquila R

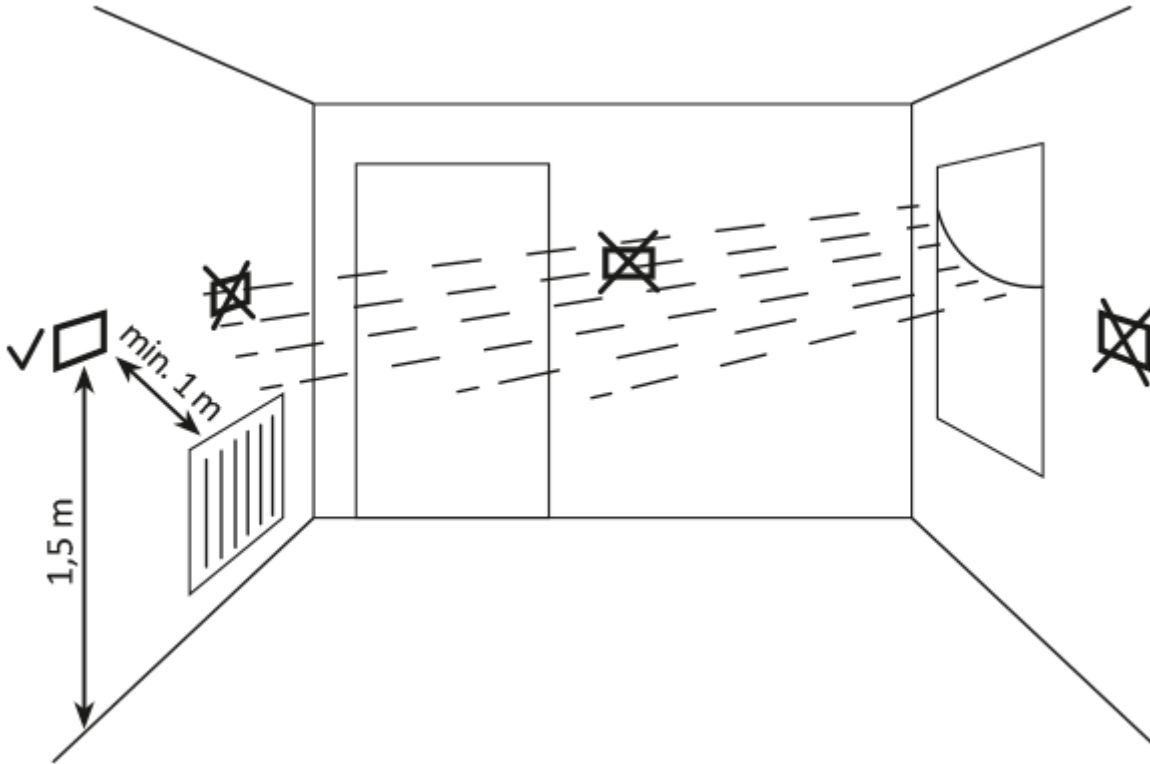

The correct operation of AURATON Aquila R is largely influenced by its location. Using the device in a place with no air circulation or a place with direct sunlight may result in incorrect temperature control. AURATON Aquila R should be installed on the internal wall of a building (a partition wall), in an environment with free air circulation. You should avoid proximity to heat-emitting devices (TV, heaters, refrigerators) or locations exposed to direct sunlight. The vicinity of doors and exposing AURATON Aquila R to possible vibrations may also cause problems with proper operation of the device.

## Battery installation/replacement

The battery sockets are located inside AURATON Aquila R on both sides of the display. To install the batteries, remove the AURATON Aquila R housing as shown in the figure.

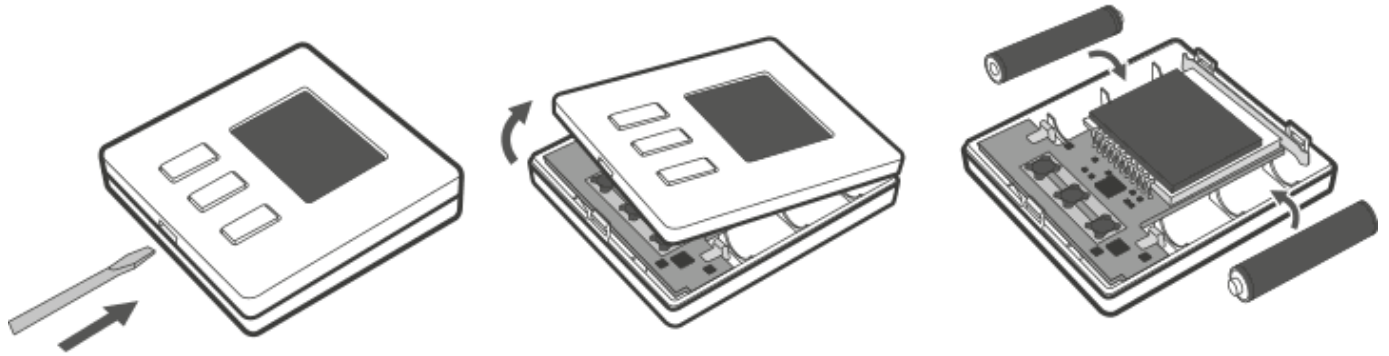

Insert two AAA 1.5V batteries into the battery socket, making sure that the battery terminals are properly aligned.

**NOTE:**

**To power AURATON regulators, we recommend alkaline batteries. Do not use “rechargeable batteries” because the voltage rating is too low.**

## Mounting of AURATON Aquila R

In order to fix **AURATON Aquila R** to the wall one should:

1. Remove the enclosure (*as shown in the “Battery Installation/replacement” section*).
2. Drill two holes of 6 mm diameter in the wall (the spacing of the holes should be determined by the rear part of the AURATON Aquila R housing).
3. Insert the wall plugs into the drilled holes.
4. Screw the back part of the AURATON Aquila R housing to the wall using the screws provided.
5. Install the batteries and attach the housing.

**NOTE:**

**In the case of a wooden wall, there is no need to use wall plugs. It is enough to drill holes with a diameter of 2.7 mm (instead of 6 mm) and screw the screws directly into the wood.**

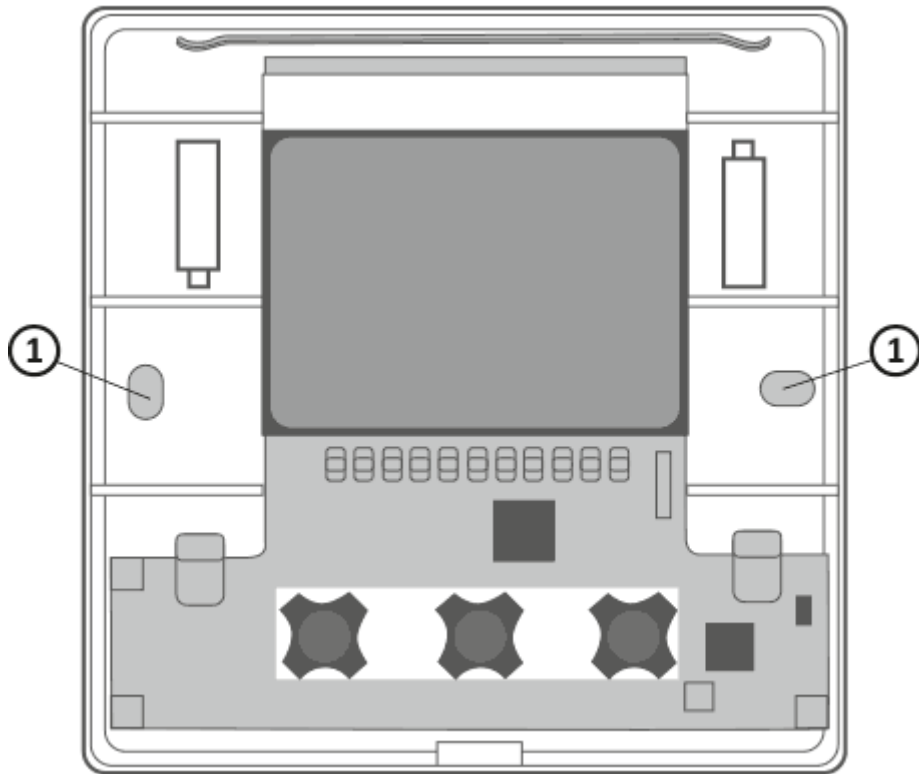

1. Holes for fixing screws.

## Alternative mounting methods

AURATON Aquila R can be fixed to a smooth surface using e.g. a double-sided tape. AURATON Aquila R can also be placed anywhere on a level surface using the stand located on the back of the housing.

## First start-up of AURATON Aquila R

When the batteries are properly inserted in the sockets, the LCD display will show all segments for a second (display test) followed by the software version number. After a moment, the current

temperature is displayed. AURATON Aquila R is ready for operation.

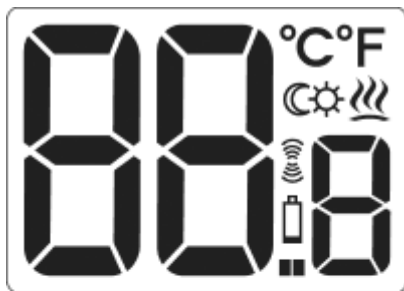





## Temperature setting

### NOTE:

The first press of any function button always turns on the backlighting, and only the next press calls up the button function.

In order to set the desired (setpoint) temperature in the normal mode of operation, you should

1. Press the  or  button. The segment responsible for the temperature display will go into edit mode, and start flashing.
2. Using the  and  buttons, set the desired (setpoint) temperature with an accuracy of 0.2 °C
3. Confirm your choice by pressing  briefly



## FrostGuard function



**AURATON Aquila R** is equipped with a special FrostGuard function protecting the room against possible freezing. This function is activated even if **AURATON Aquila R is switched off.**

With AURATON Aquila R switched off, when the temperature in the room drops to 2 °C, the symbols (Fr) appear on the display, and a signal is sent to the head, which will switch on the heating. When the temperature rises to 2.2 °C, the display turns off again, and a signal is sent to the head unit to switch off the heating.

## Set the temporary temperature lowering mode



If you would like to lower the room temperature by 3 °C every day at the same time, there is a possibility of temporary temperature reduction for a period of 6 hours. In order to do this you need to:

1. Press and hold both   buttons for 3 seconds. The moon symbol (☾) will appear on the display.
2. AURATON Aquila R enters the temporary temperature lowering mode, and every day **at the same time** it will reduce the temperature programmed in the normal mode by 3 °C for a period of 6 hours.





**NOTE:**

After 6 hours, AURATON Aquila R returns to the basic temperature setting. Instead of the moon symbol (☾), the sun symbol (☀) will appear on the screen.

**NOTE:**

The “temporary temperature lowering ” mode always starts when the function is activated. This means that a possible temporary temperature reduction should be programmed at the time when we you such a change to take place.

## Deactivating the “temporary temperature lowering” mode

To deactivate the “temporary temperature lowering” mode, press the   buttons again for 3 seconds.

The moon (☾) or sun (☀) symbol will be turned off on the display, and only the room temperature will remain displayed. AURATON Aquila R has returned to normal operation mode.

## Description of the AURATON Fornax

### weekly, wired thermostat (transmitter)

AURATON Fornax (receiver) cooperates with the wireless AURATON Aquila R regulator (transmitter). The receiver is mounted next to the heating device and can work under a load up to **16 A/10 A** .

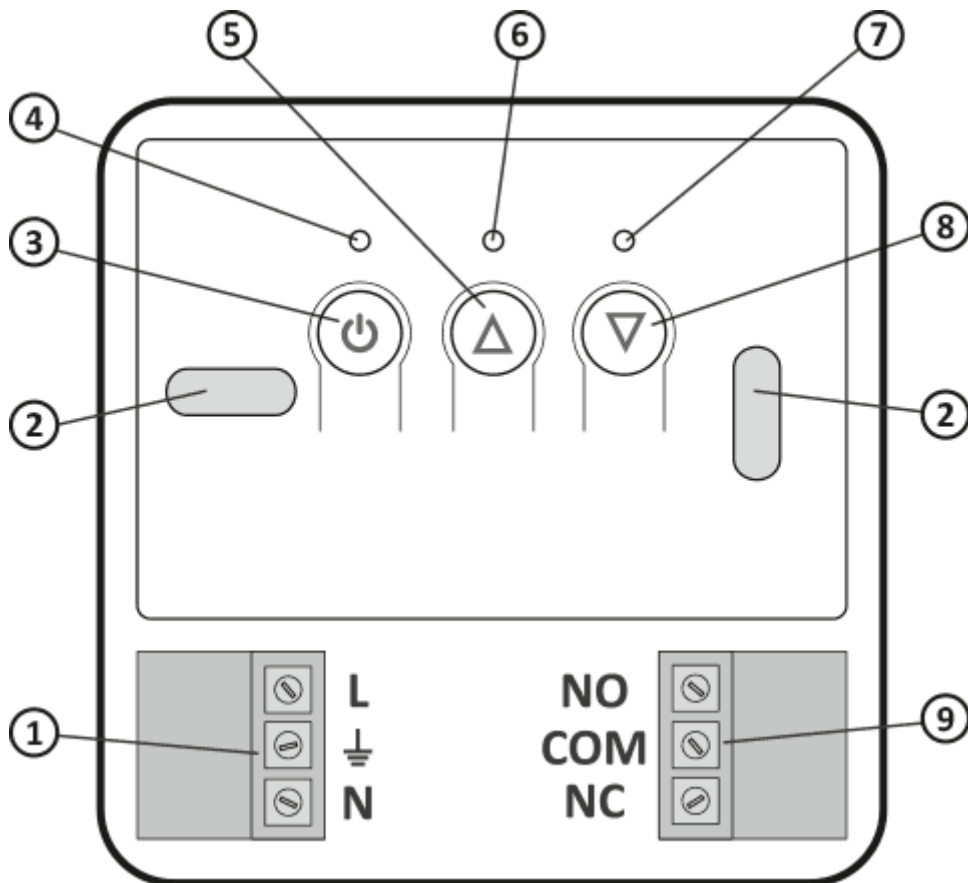

1. Detachable power connector terminals 230 V AC
2. Mounting hole
3. Power button
4. Power supply diode
5. Button to unpair devices
6. Diode indicating that the actuator device is switched on
7. Diode indicating that the actuator device has been switched off
8. Button to pair devices with the receiver
9. Control connectors

### Legend - description of diode signalling

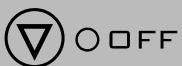

**The diode is green** - the actuator device is switched off (the COM and NC contacts are closed).



**The diode is red** – the actuator device is switched on (the COM and NO contacts are closed).



**The diode is blinking green** – the AURATON Fornax receiver is waiting for device pairing – *chapter: “Pairing the AURATON wireless thermostat (transmitter) with AURATON Fornax – heating device controller (receiver)”*.



**The diode is blinking red** – the AURATON Fornax receiver is waiting for the previously paired device to be unpaired – *chapter: “Unpairing a thermostat paired with AURATON Fornax – heating device controller (receiver)”*.



**The LED alternates blinking red and green:**

**ALARM** – the AURATON Fornax receiver has lost connection with the paired device – *chapter: “Special cases”*

**RESET** – the AURATON Fornax receiver.

Removal of all devices paired with the AURATON Fornax receiver – heating device controller.



**Green power diode** – the AURATON Fornax receiver is on.

## Mounting AURATON Fornax - heating device controller (receiver)



### **WARNING!**



**The cables supplied with the thermostat are designed to transfer a load of max. value of 2.5 A.**

In the case of connecting devices with higher power, they should be replaced with wires of appropriate cross-section.

### **NOTE:**

while installing the AURATON Fornax receiver, the power supply should be turned off. It is recommended to entrust the installation of the receiver to a specialist.

### **NOTE:**

There must be a switch and overcurrent protection in the fixed building installation.

**NOTE:**

For easier installation, the connections are equipped with pull-out clips. Before connecting wires, you can disconnect them from AURATON Fornax. Wires can be routed from the bottom of AURATON Fornax after holes are punched in the mounting plug or from the back of AURATON Fornax if the wires are pulled out of the wall. To connect from the back, break the plug.

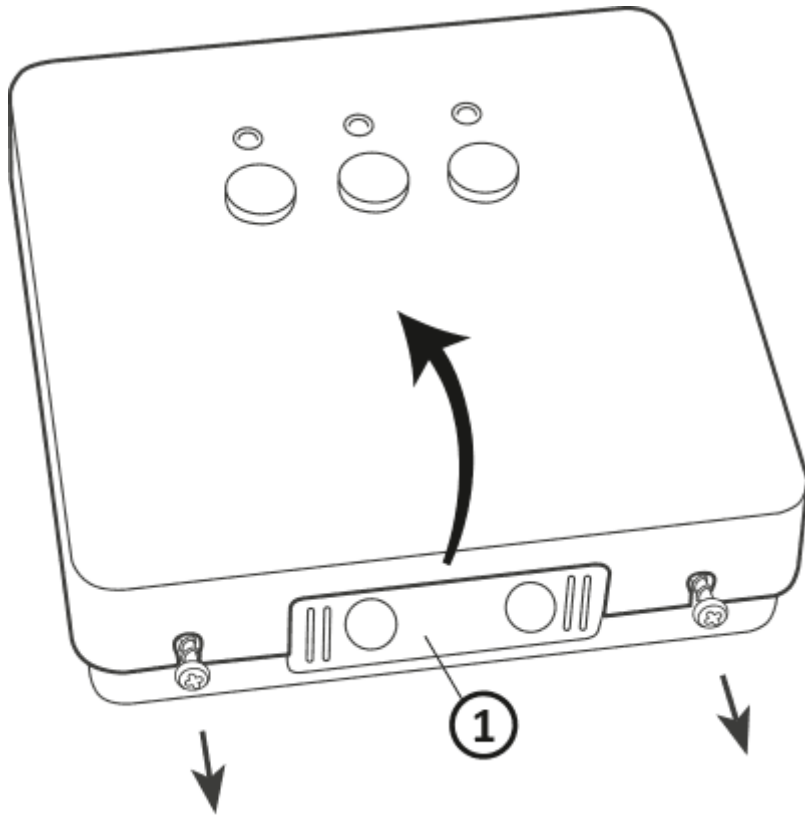

1. mounting plug

Remove the cover of the front part of Auraton Fornax by unscrewing the screws halfway.

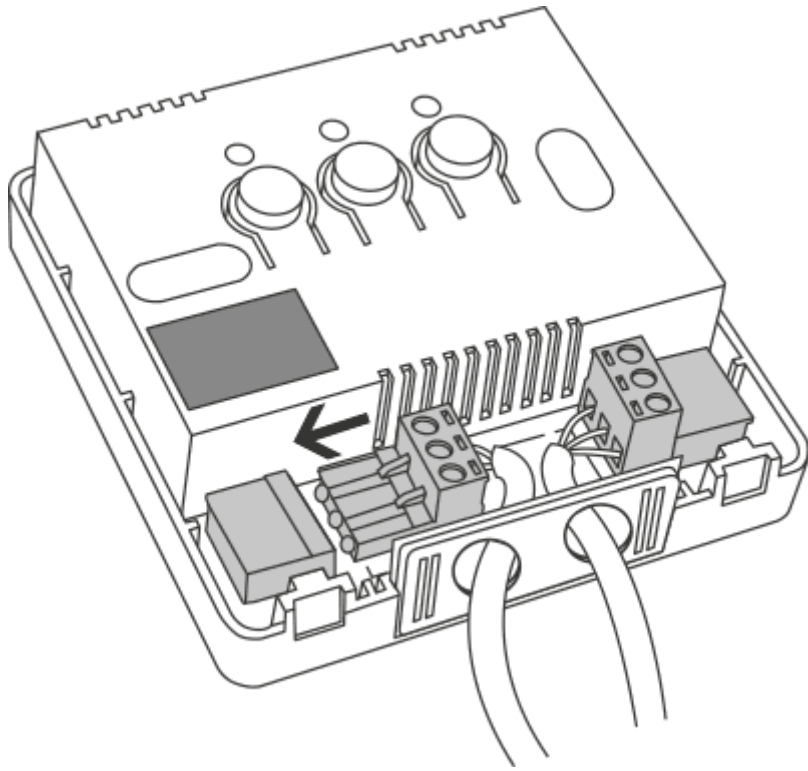

Connect the heating device to the clips of the AURATON Fornax control connector. Follow the service manual of the heating device. COM (common) and NO (normally open circuit) clips are most commonly used.

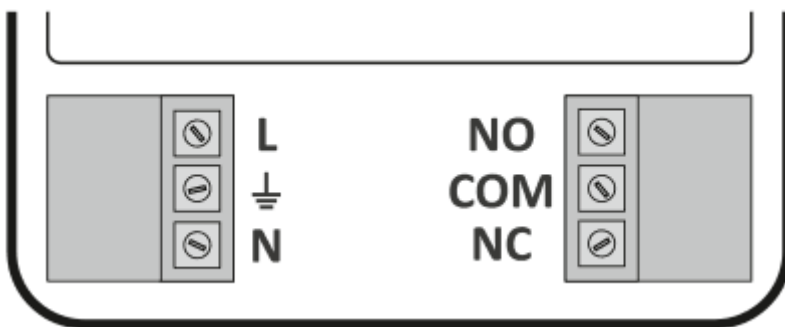

Connect the power supply wires to the clips of the power supply connector of the AURATON Fornax

receiver, observing safety rules.

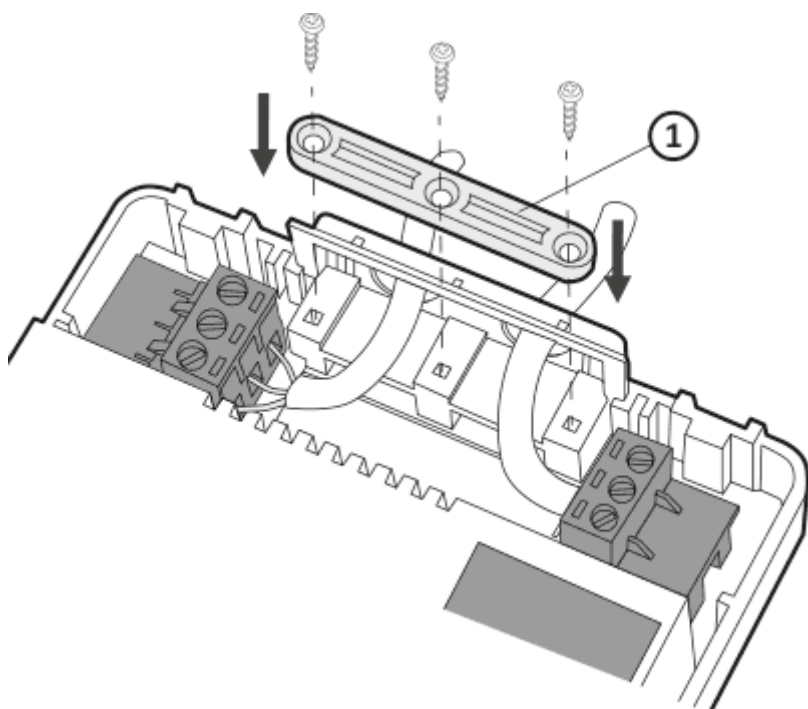

1. Wire mounting bracket.

Once the wires are connected, secure them with the “wire mounting bracket” and screw the cover back onto the AURATON Fornax receiver.

**Mounting AURATON Fornax - heating device controller (receiver) onto a wall**

To fix AURATON Fornax to a wall:

1. Remove the cover from the front part of the receiver see *chapter "Mounting the AURATON Fornax receiver heating device controller (receiver)"*.
2. Mark the location of the holes for the mounting screws on the wall.
3. Drill holes with diameters of the attached plugs (5 mm) where marked.
4. Insert wall plugs into the drilled holes.
5. Screw the AURATON Fornax receiver to the wall with the screws, so that the device is fixed securely.

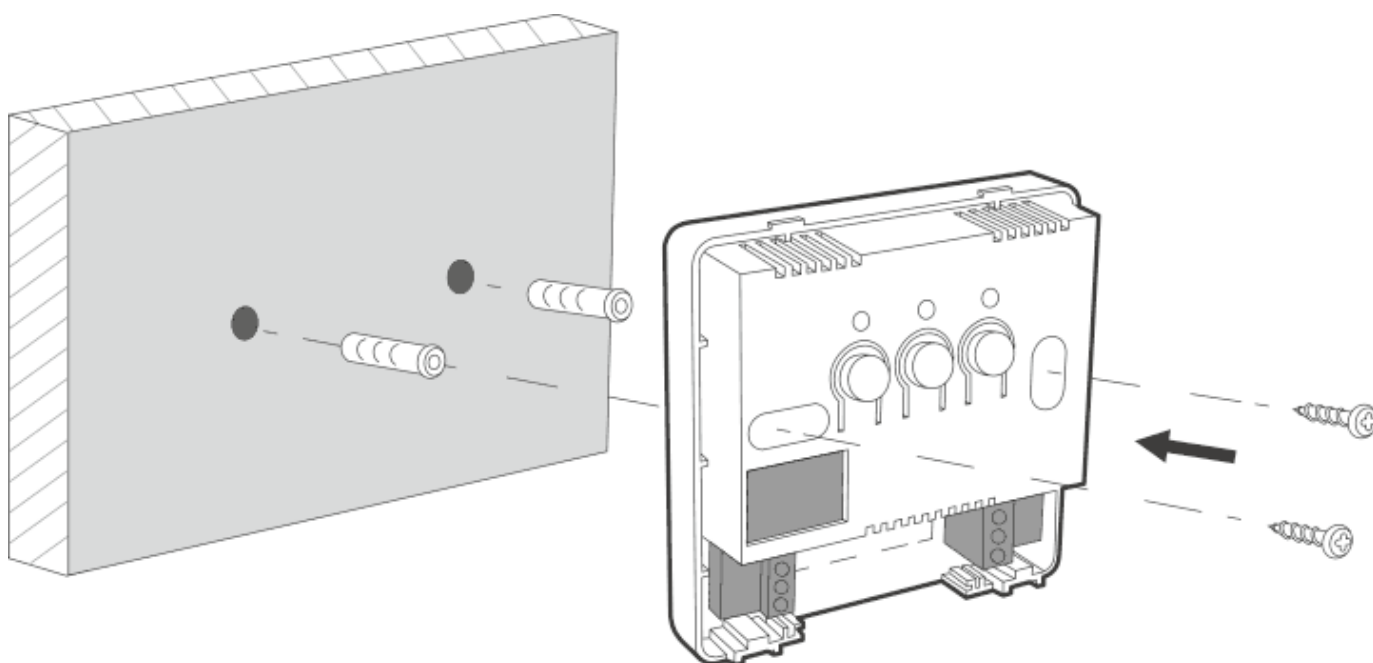

**NOTE:**

If the wall is wooden, there is no need to use wall plugs. Drill holes with a diameter of 2.7 mm instead of 5 mm and put the screws directly into the wood.

**NOTE:**

Do not place AURATON Fornax in metal housings (e.g. mounting box, metal housing of a furnace), so as not to interfere with the thermostat's operation.

## Pairing

# the weekly, wireless thermostat (transmitter) AURATON Aquila R with the wireless heating device controller (receiver) AURATON Fornax

After connecting to the mains, switch the receiver on by briefly pressing the power button (🔌). When the device is switched on, the green power diode lights up, and there is an audible single sound signal. To switch off the receiver e.g. outside the heating season, hold down the power button for 3 seconds until there is an audible double sound signal, and the green power diode switches off, which means that the heating device has also been switched off.

### NOTE:

The AURATON Aquila R wireless regulator sold together with the AURATON Fornax receiver is already paired. Devices purchased separately require “pairing”.

1. Pairing AURATON Aquila R with an AURATON Fornax receiver is initiated by pressing the right pairing button – a single beep (🔻) on the AURATON Fornax receiver and holding it for at least 3 seconds until the LED starts flashing green (a double beep), then releasing the button.  
*The AURATON Fornax receiver will wait 120 seconds for pairing. After this time elapses, it will automatically return to normal operation.*
2. On the AURATON Aquila R, press simultaneously the 🔽🔌 or 🔼🔌 buttons for 6 seconds until the transmitting symbol (📶) lights up on the display.
3. Successful completion of pairing is signalled when the green LED diode on the AURATON Fornax receiver is no longer blinking, a single sound signal is heard, and the receiver returns to normal operation.

*If there is a pairing error, please repeat steps 1 and 2. In the event of further errors, perform a RESET of the AURATON Fornax receiver (see “RESET - Restoring the AURATON Fornax receiver to factory settings”) and try to pair the AURATON Aquila R again.*

### NOTE:



The Auraton Fornax receiver can be paired with only one AURATON Aquila R.







## Signalling the working status and data package reception

Each reception of radio transmission from paired AURATON Aquila R is signalled by the AURATON Fornax receiver with a momentary alternating change of colour of LED diodes. When the relay is turned on, the LED is red, and when the relay is turned off, the LED is green.

### NOTE:

Pressing a button is signalled by a short sound signal.

## Unpairing of AURATON Aquila R - daily wireless temperature regulator (transmitter) with AURATON Fornax

1. Unpairing of AURATON Aquila R with AURATON Fornax is initiated by pressing the left pairing button (  ) on the receiver and holding it for at least 3 seconds, until the LED starts blinking red, then release the button. The sound signalling works in the same way as during pairing, i.e. pressing the button is signalled by a short sound followed by a double short sound signal after 3 seconds.  
*The AURATON Fornax receiver waits for unpairing of the AURATON Aquila R 120 s. After that time, it automatically returns to normal operation.*
2. Press the   or   button simultaneously on the AURATON Aquila R for 6 seconds until the transmit symbol (  ) lights up on the display.
3. Successful completion of unpairing is signalled when the red LED diode on the AURATON Fornax receiver is no longer blinking, a single sound signal is heard, and the receiver returns to normal operation.

If an error occurs during unpairing of AURATON Aquila R, repeat steps 1 and 2. In case further errors occur, perform RESET of AURATON Fornax (see “RESET – Returning AURATON Fornax to factory settings”).

## RESET - Returning AURATON Fornax to factory settings

In order to perform a reset to the factory settings in AURATON Fornax, both pairing and deleting buttons (▽ ▲) should be pressed simultaneously and held for at least 5 seconds. until LED signalling changes to alternate blinking in green – red colours. Then release both buttons. Sound signals: pressing the button, a short sound signal – after 5 seconds, a double short sound signal.

Successful completion of the reset is signalled after approx. 2 seconds by the change of signalling to green, followed by switching it off for a short time.

### NOTE:

If you disconnect AURATON Fornax from the power supply after RESET, and then reconnect the power supply, AURATON Fornax will automatically go into the “pairing” mode for 120 seconds. AURATON Fornax, which is newly purchased (not purchased together with the AURATON Aquila R) without a factory paired regulator, will behave identically.

## Hysteresis change

The hysteresis is intended to prevent the executive device from switching on too frequently due to minor temperature fluctuations.

*For example, for the **HI 2** hysteresis, if the temperature is set to 20 °C, it will be switched on at 19.8 °C and switched off at 20.2 °C. For the **HI 4** hysteresis, when the temperature is set to 20 °C, it will be switched on at 19.6 °C and off at 20.4 °C.*

To enter the hysteresis change mode, press ▾, ▲ and  buttons simultaneously for 3 seconds. The hysteresis change mode is signalled by flashing **HI**. Use the ▾, ▲ buttons to change the hysteresis setting.

**HI 2** – ±0,2 °C (factory set)

**HI 4** – ±0,4 °C

**HI P** – PWM mode of operation (chapter “PWM mode of operation”).

Confirm the selection with the  button. AURATON Aquila R will return to normal operation.



## **PWM working mode**

(Pulse-Width Modulation)

By changing the hysteresis settings (*chapter "Configuration settings"*) you can enable the PWM mode. In this mode, AURATON Aquila R cyclically switches on the heating device in order to minimize temperature fluctuations. AURATON Aquila R checks the times of temperature rise and times of temperature fall.

Knowing these values, the AURATON Aquila R switches the heating device on and off in such cycles as to maintain the temperature as close to the setpoint value as possible.

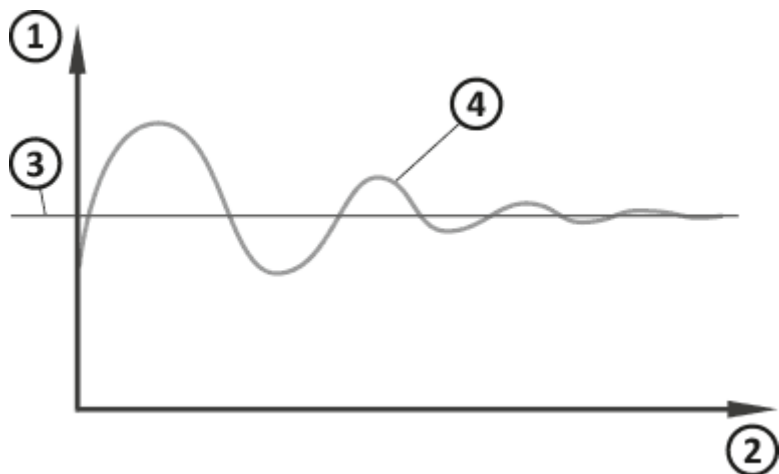

1. Temperature
2. Time
3. Set temperature
4. Room temperature

**NOTE:**

In the PWM mode, the AURATON Aquila R can switch on the heating device despite the fact that the room temperature is higher than the setpoint temperature. This is due to the PWM algorithm seeking to maintain the setpoint temperature and anticipating the behaviour of the thermal system.

## Operation of the Fornax receiver with a heating device

### Basic device configuration

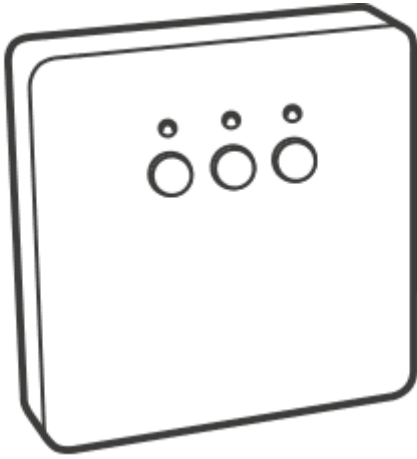

**AURATON Fornax**  
Receiver connected  
to the heating device

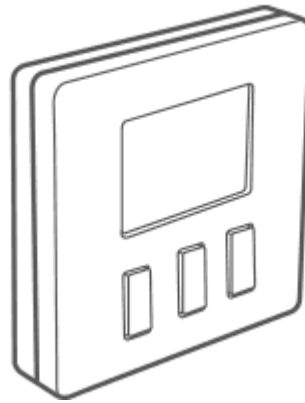

**AURATON Aquila R**  
daily wireless temperature regulator.

### Diagram of connection of AURATON Fornax

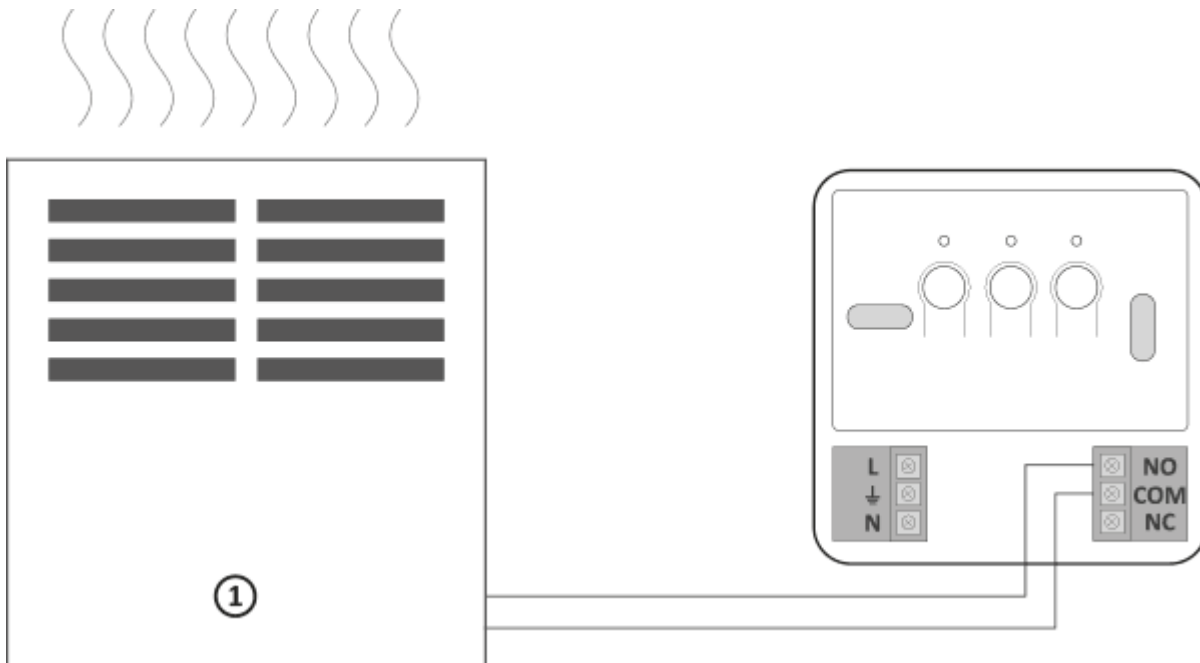

1 - Heating device

## Special cases

- When three consecutive transmissions are lost (after 15 minutes) from AURATON Aquila R, the failure is signalled on the AURATON Fornax receiver (continuous blinking of the LED diode alternately in red and green colours). Until the problem is rectified, the Fornax receiver will go into a memorised on/off cycle of the last 24 hours.
- When the signal from AURATON Aquila R returns, the error is cancelled, and the receiver returns to normal operation.



## Unique features of AURATON Fornax

- Relay switching is synchronised with the 230 V AC power supply line so that the closing and opening of the relay armature contacts always occurs in the area of the voltage waveform reaching zero. This prevents the formation of an electric arc and significantly extends the life of the relay.
- The AURATON Fornax receiver is equipped with a unique algorithm for analysing the on/off cycles. The entire heating cycle from the last 24 hours is stored in AURATON Fornax memory. In the event of loss of communication with the AURATON wireless thermostat (transmitter), AURATON Fornax will automatically execute the stored on/off cycle from the last 24 hours. This gives you time to restore the transmission (solve issues with interference) or repair the thermostat without a significant deterioration of the thermal comfort in the controlled facility.

## Additional information

- AURATON Aquila R must be installed at least 1 metre away from AURATON Fornax (too strong a signal from the transmitter may cause interference).
- At least 30 seconds must elapse between turning the relay off and on.
- Data transmission from AURATON Aquila R to AURATON Fornax takes place every time the ambient temperature changes by 0.2°C. If the temperature does not change, AURATON Aquila R transmits control data every 5 minutes (it manifests itself by momentary blinking of diodes on the Fornax receiver – alternately).
- In the event of a power failure, AURATON Fornax will switch off. When power is restored, AURATON Fornax will automatically turn on and wait for the nearest signal from the paired AURATON Aquila R (this signal should arrive no later than 5 minutes after power is restored).

When the signal is received, the Fornax receiver will proceed to normal operation.

- Do not place the Fornax receiver in metal housings (e.g. installation box, metal furnace housing) so as not to interfere with AURATON Aquila R operation.
- AURATON Aquila R can be switched on or off at any time by momentarily holding down the  button.
- The first press of any function button always turns on the backlighting, and only the next press calls up the button function.
- When programming any function in AURATON Aquila R, not pressing any button for 10 seconds is equivalent to pressing .

## Cleaning and maintenance

1. Clean the outside of the device with a dry cloth. Do not use solvents (such as benzene, thinner or alcohol).
2. Do not touch the device with wet hands. It may result in an electric shock or serious damage to the device.
3. Do not expose the device to excessive smoke or dust.
4. Do not touch the screen with a sharp object.
5. Avoid contact of the device with liquids or moisture.

## Diagram of connection of receiver

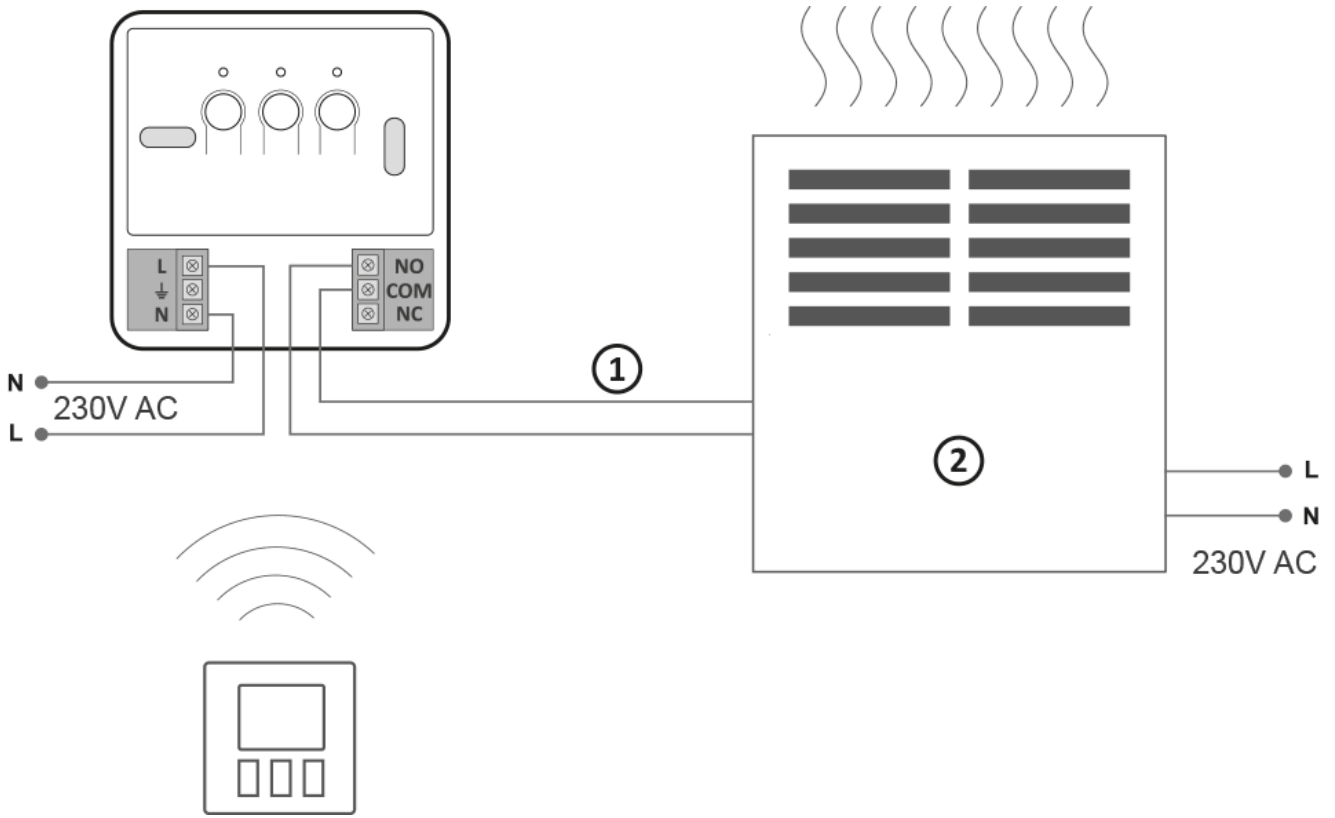

1 - Control

2 - Heating device, e.g. a gas furnace



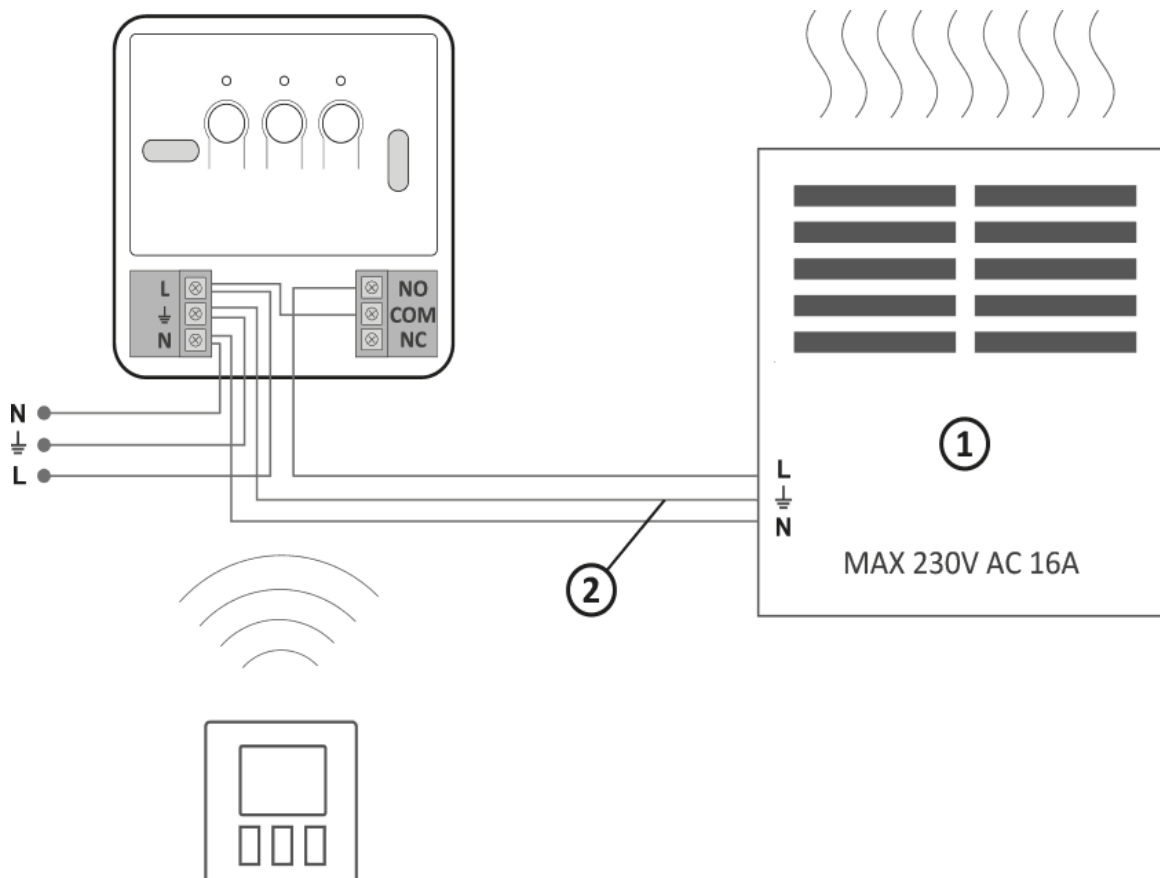

1 - Electric heating or air conditioning device

2 - protective (⏚)

## Technical specifications

Working temperature range: 0 - 45 °C

Operation range: in a typical building with standard wall construction - approx. 30 m;  
in open space - up to 300 m

Radio frequency: 868.850 MHz  
869.000 MHz

Radio signal strength: Up to 11 dBm

Level of security: IP20

## AURATON Aquila R:

Power supply:	2 x AAA (2 x 1.5 V), alkaline
Working status signaling:	LCD display
Number of temperature levels:	1
Anti-freeze temperature:	2 °C
Temperature measurement range:	0 - 35 °C
Temperature control range:	5 - 30 °C
Hysteresis:	±0.2 °C/±0.4 °C/PWM
Working cycles:	Daily
Dimensions [mm]:	70 x 70 x 14.5

## AURATON Fornax:

Power supply:	230 V AC, 50 Hz, 1,5 W
Working status signaling:	LED indicators, sound
Relay load capacity:	Max. 250 V AC, max. 16 A
Receiver Category:	2
Suggested installation location:	Near the heating or air conditioning device
Dimensions [mm]:	100 x 100 x 29

## Disposing of the devices

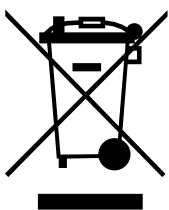

The devices are marked with the crossed-out wheeled bin. According to European Directive 2012/19/EU and the Waste Electrical and Electronic Equipment Act, this kind of marking indicates that the equipment, after its operational life must not be disposed of together with other waste from households.

**The user shall return it to a collection point for electrical and electronic waste.**

Hereby, LARS Andrzej Szymanski declares that the radio equipment type AURATON Aquila SET is in compliance with Directive 2014/53/EU and 2011/65/EU. The full text of the EU declaration of conformity is available in the download section below.

---

## Contact and address of the manufacturer

### Lars

ul. Świerkowa 14  
64-320 Niepruszewo  
Polska  
[www.auraton.pl](http://www.auraton.pl)

---

---

## Download

- [User manual](#)
- [Declaration of conformity AURATON Aquila R](#)
- [Declaration of conformity AURATON Fornax](#)