



## AURATON Libra DS

User manual ver. 20220222

The document presents collected information on safety, assembly and use of AURATON Libra DS.

---

### Weekly, wired thermostat (dual sensor)

AURATON Libra DS is a weekly, wired thermostat with an additional external temperature sensor on the wire. Works with a gas or electric heating device. Designed to control underfloor heating.



**3 independently adjustable temperatures**  
Day, night, anti-freezing.



**9 independent temperature programs**  
Including 6 user-modifiable programs.

**LCD**

**Backlit LCD display**

The backlit display allows you to supervise the operation of the device even in poorly lit rooms.

# Description of the AURATON Libra DS

## Weekly, wired thermostat

There is a backlit LCD display, four function buttons and a temperature setting knob with an **OK** button on the front part of the regulator's casing.

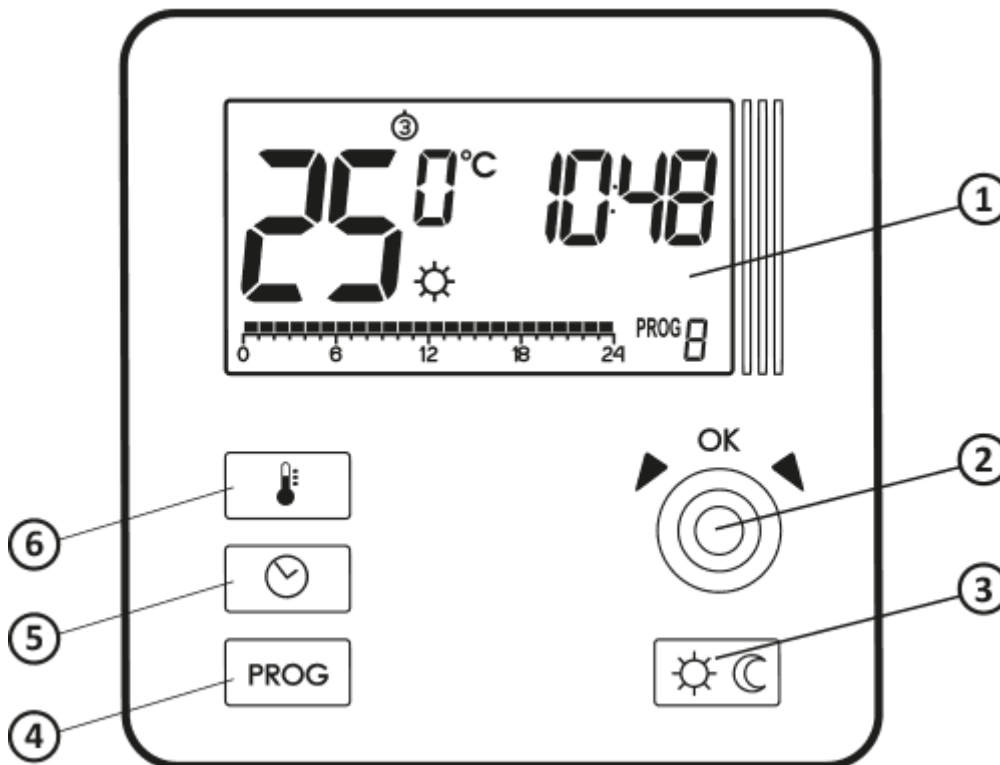

1. LCD display
2. setting knob with integrated **OK** button
3. mode selection buttons:
  - ☀ - day mode - comfort,
  - ☾ - night mode - economic
4. selection button
5. date/time/day of week setting button
6. temperature setting button

## Display

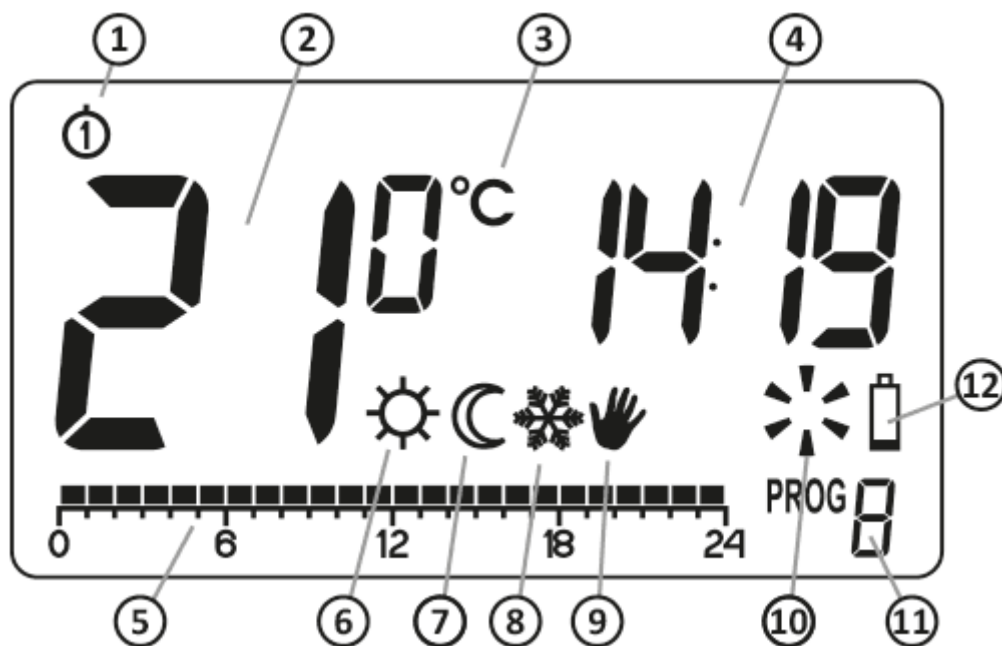

1. **Day of the week** (①-⑦) - Indicates what day of the week it is. Each day is assigned a number.
2. **Temperature** - AURATON Libra DS displays the temperature of the room in which it is installed in normal operation mode.
3. **Temperature unit** - tells you that the temperature is displayed in Celsius degrees (°C).
4. **Clock**  
Time is displayed in a 24-hour system.
5. **Timeline**  
Program progress indicator. The timeline is divided into 24 segments, each of which corresponds to one hour. It shows how a given program is implemented. (see chapter "Timeline")
6. **Day mode indicator** (☀)  
Indicates that AURATON Libra DS is operating in the day mode. (see chapter "Temperature programming")
7. **Night mode indicator** (☾)  
Indicates that AURATON Libra DS is operating in the night mode. (see chapter "Temperature programming")
8. **Anti-freezing mode indicator** (❄)  
Indicates that AURATON Libra DS is operating in the anti-freezing mode. (see chapter "Anti-freeze mode")
9. **Manual control indicator** (✋)  
Appears when no program is used. (see chapter "Manual control mode")
10. **AURATON Libra DS activation indicator** (❄)  
Segment giving information about the operating status of AURATON Libra DS. Visible when the regulator is turned on.
11. **Program number**

Indicates the number of the currently running program. (see chapters "Factory programs" and "Weekly programming")

## 12. Dead batteries (🔋)

The indicator is visible when the minimum permissible battery voltage level is exceeded. The batteries need to be replaced as soon as possible.

### **IMPORTANT:**

**In order to maintain any programmed parameters, the battery replacement operation should not exceed 30 seconds.**

## Choosing the right location for AURATON Libra DS

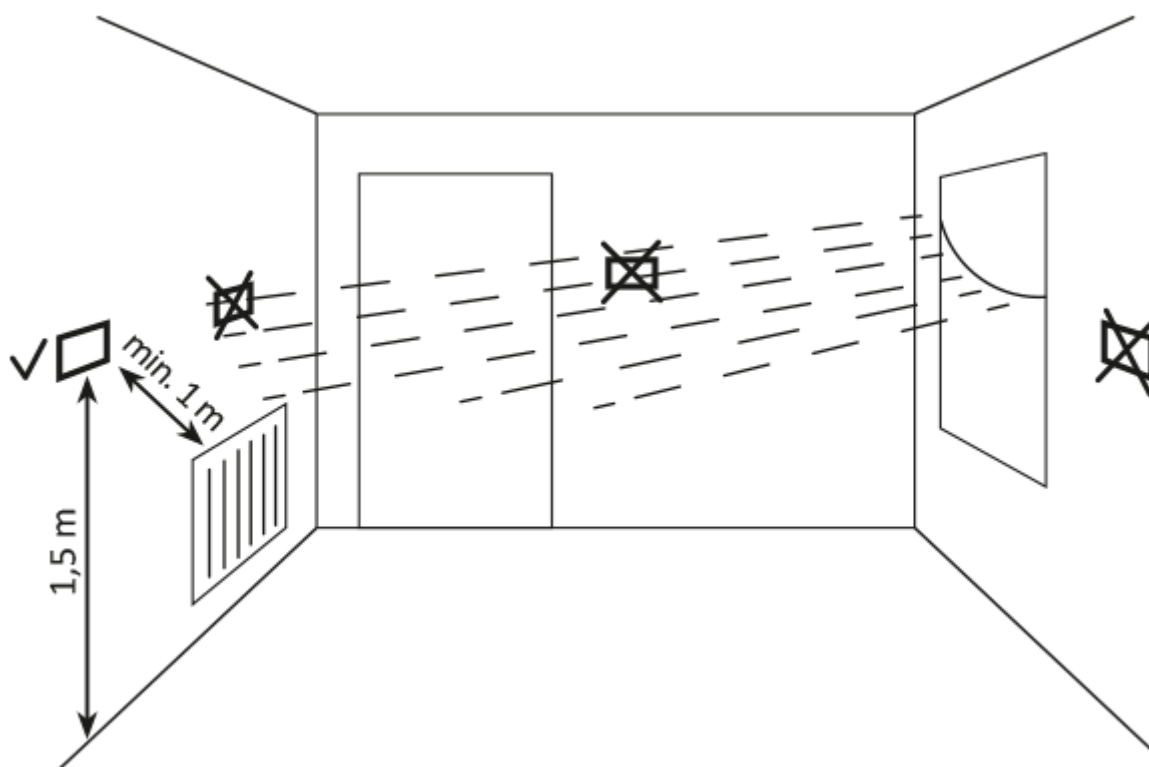

The correct operation of AURATON Libra DS is largely influenced by its location. Using the device in a place with no air circulation or a place with direct sunlight may result in incorrect temperature control. AURATON Libra DS should be installed on the internal wall of a building (a partition wall), in an environment with free air circulation. You should avoid proximity to heat-emitting devices (TV,

heaters, refrigerators) or locations exposed to direct sunlight. The vicinity of doors and exposing AURATON Libra DS to possible vibrations may also cause problems with proper operation of the device.

## Connecting cables to AURATON Libra DS

To connect the wires, remove the casing as shown below:

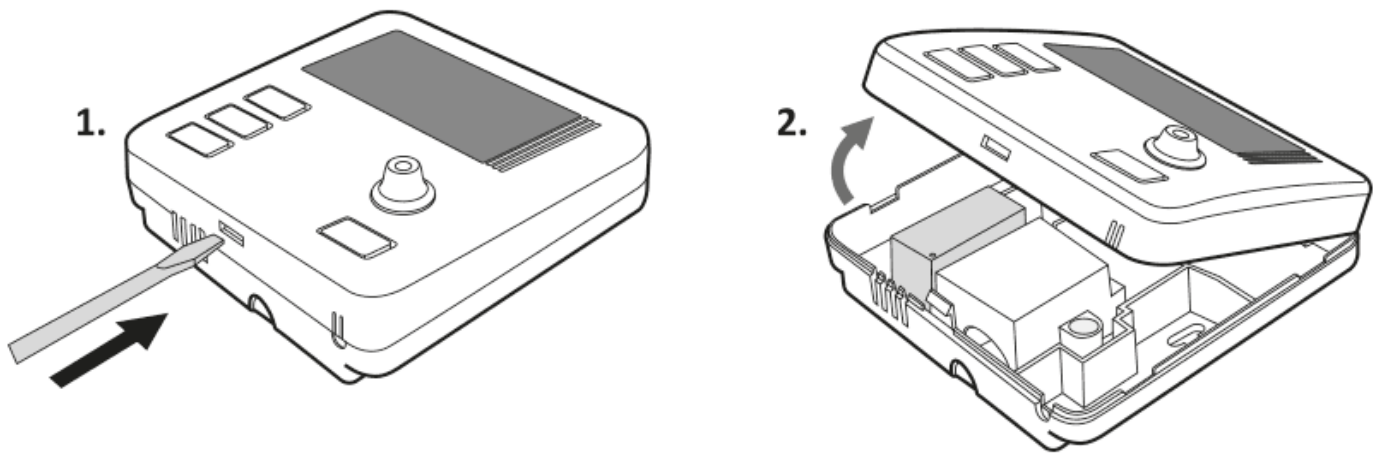

The terminals are located on the back of AURATON Libra DS, **under the plastic casing**.

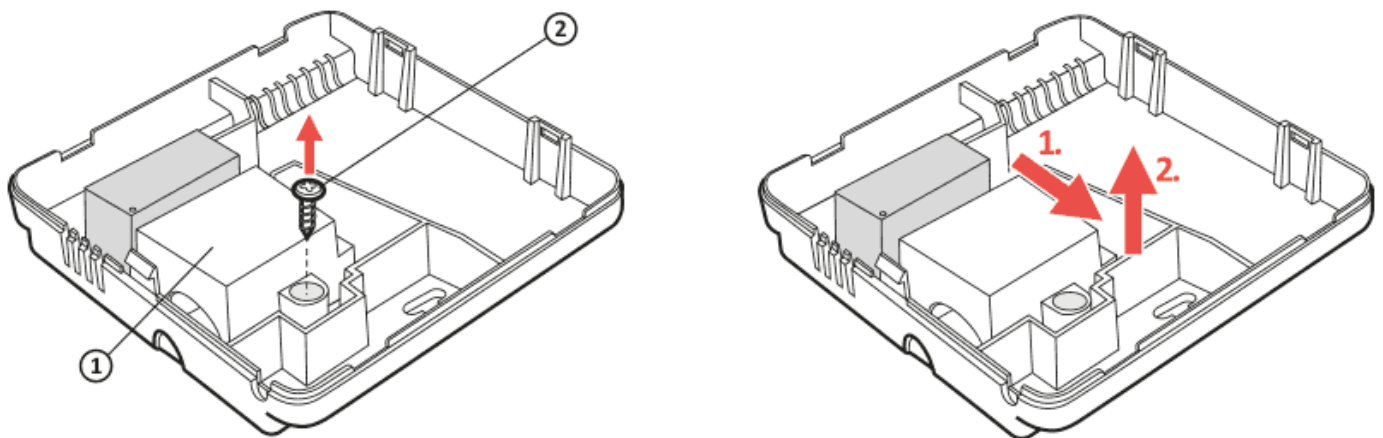

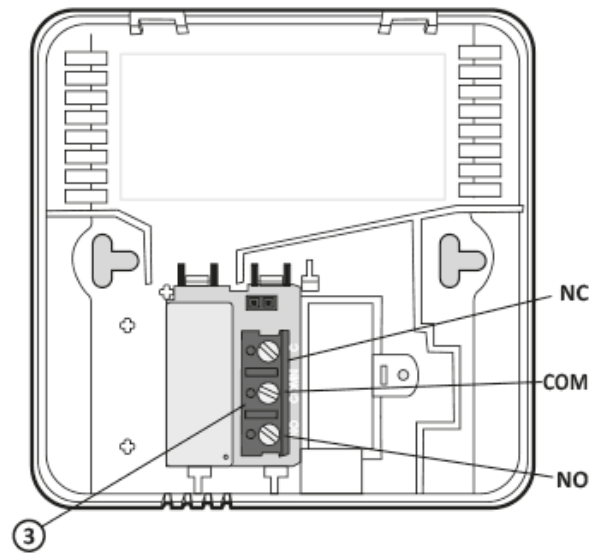
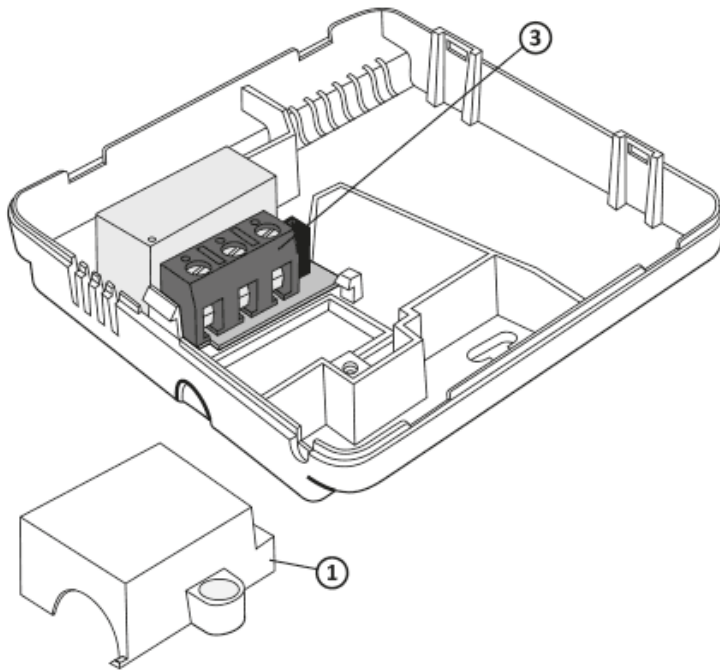

1. cover
2. screw
3. wire terminals

It is a typical single-pole double-throw relay. In most cases, the NC terminal is not used.

**IMPORTANT:**

After connecting the wires, place the plastic casing back on.

## Battery replacement

The battery compartment is located inside AURATON Libra DS in the front of the casing. To install the batteries, remove the casing of AURATON Libra DS as shown in the figure below:

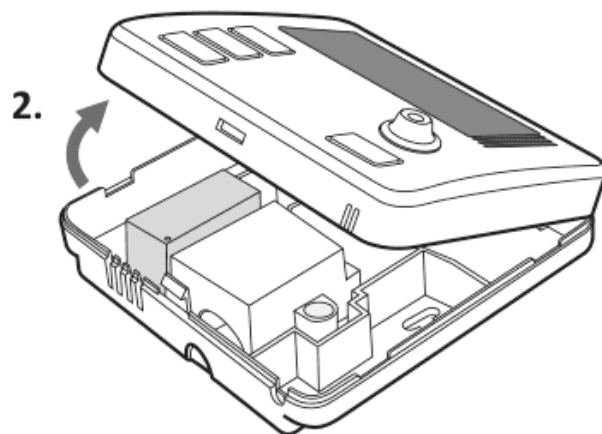
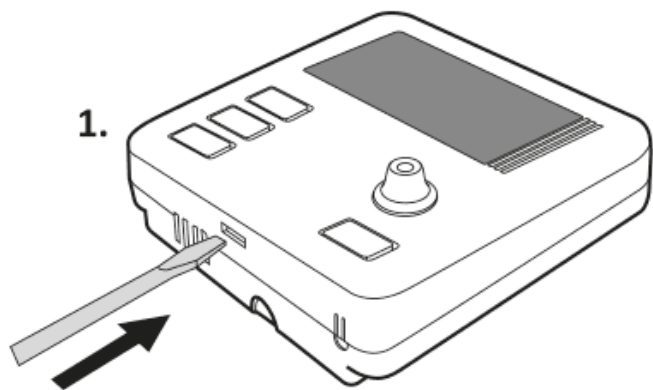

**IMPORTANT:**

We recommend using alkaline batteries to power AURATON regulators. Do not use "rechargeable batteries" because their rated voltage is too low.

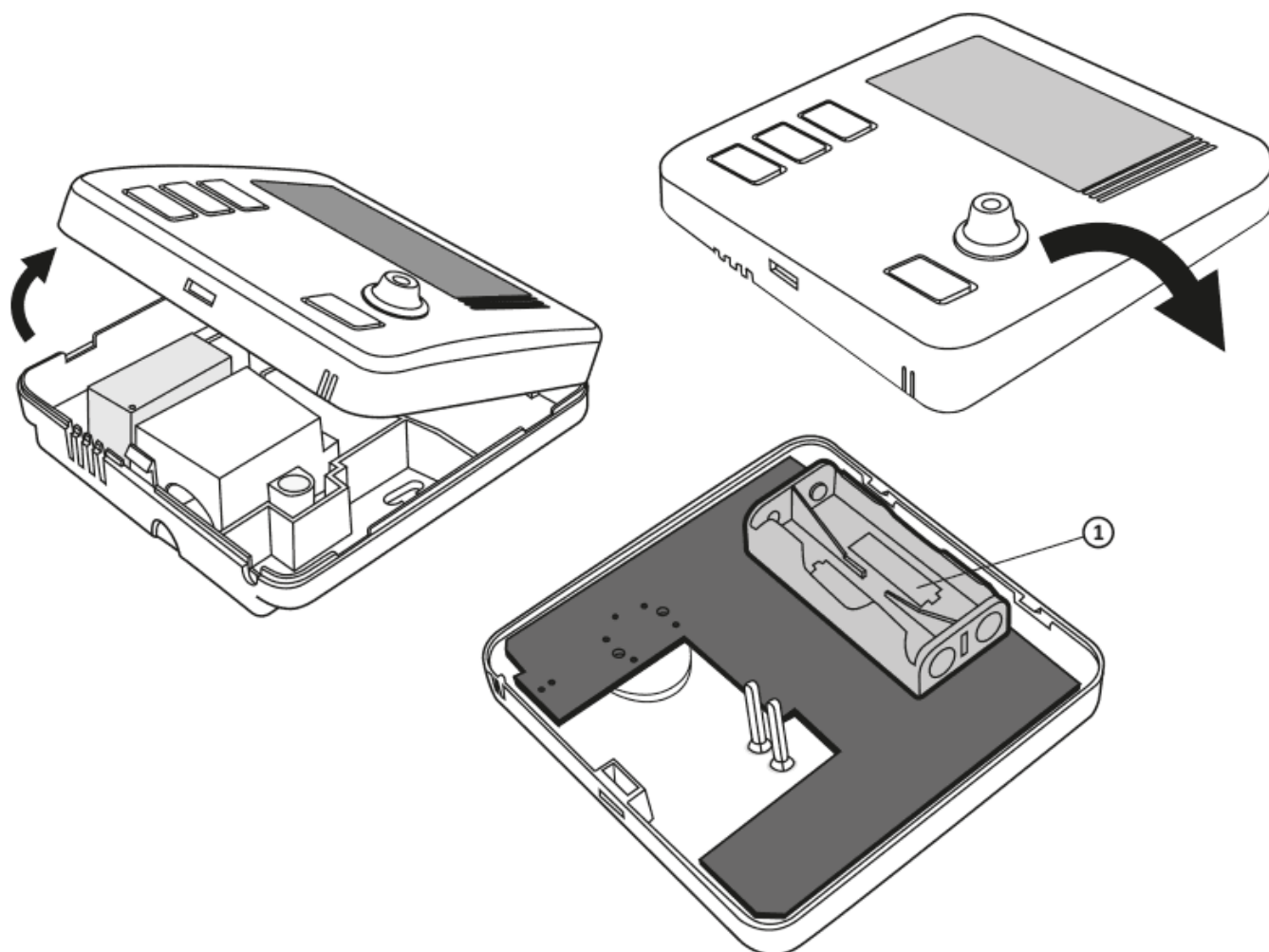

1. AAA 1.5 V battery socket

Insert two 1.5V AAA batteries into the battery compartment, paying attention to the correct polarity of the batteries.

**IMPORTANT:**

After replacing the battery and assembling the cover, we recommend pressing the OK button twice to stabilise the relay operation.

## **Mounting AURATON Libra DS - the weekly, wired temperature regulator**

In order to mount AURATON Libra DS on the wall:

1. Remove the casing (*as shown in the "Battery Replacement" section*)
2. Drill two holes with a diameter of 6 mm in the wall (*mark the spacing between the holes using the rear part of the AURATON Libra DS casing*).
3. Put wall plugs in the drilled holes.
4. Fix the rear part of the casing of AURATON Libra DS to the wall using the screws included in the kit.
5. Put the casing on.

**IMPORTANT:**

In the case of a wooden wall, there is no need to use wall plugs. It is enough to drill holes with a diameter of 2.7 mm (instead of 6 mm) and screw the screws directly into the wood.



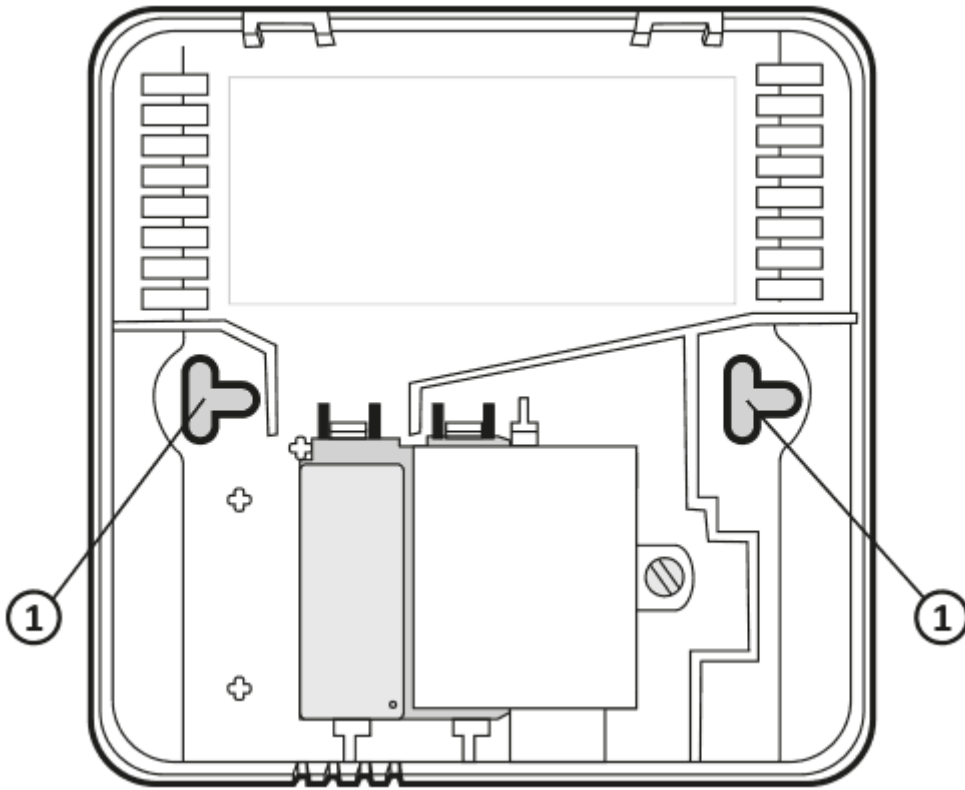

1. hole for fastening screw

### Putting the casing back on: IMPORTANT

Pay attention to the pins that transmit control to the relay when putting the front part of the casing to the rear part.

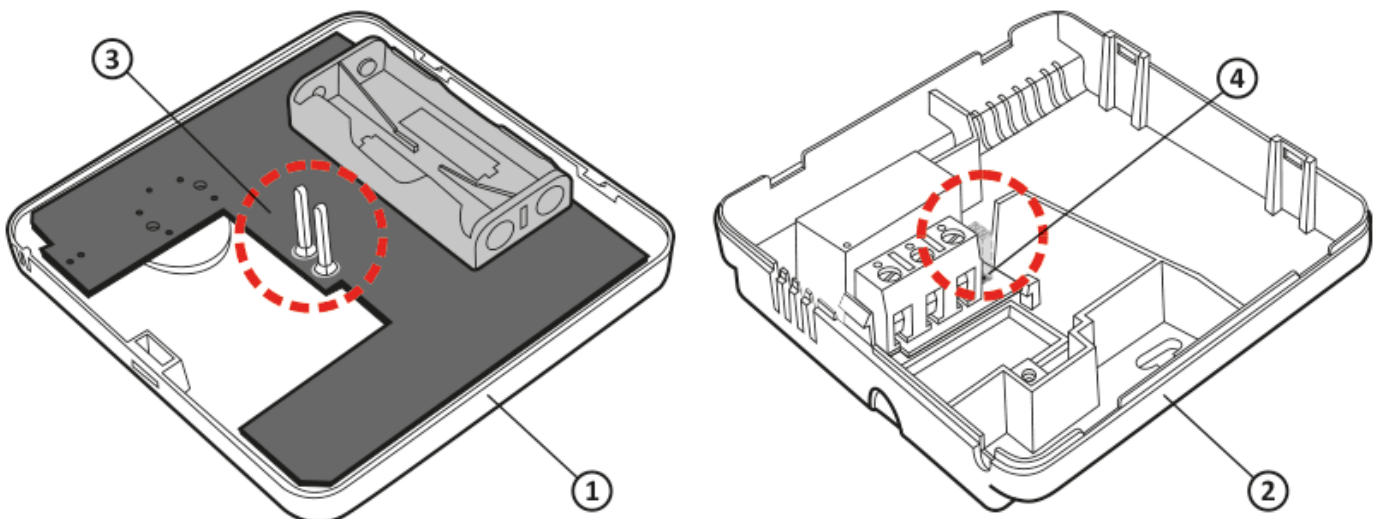

1. Front casing
2. Rear casing
3. Pins
4. The socket of the pin connector or the place where the pins contact the board

**IMPORTANT:**

Make sure that the “pins” are not bent and that they are placed in the correct spots on the relay board when assembling the casing. This is crucial for the proper operation of AURATON Libra DS.

## Turning AURATON Libra DS on for the first time

After inserting the batteries correctly into the battery compartment, the LCD screen will display all the segments for a second and then the software version number.

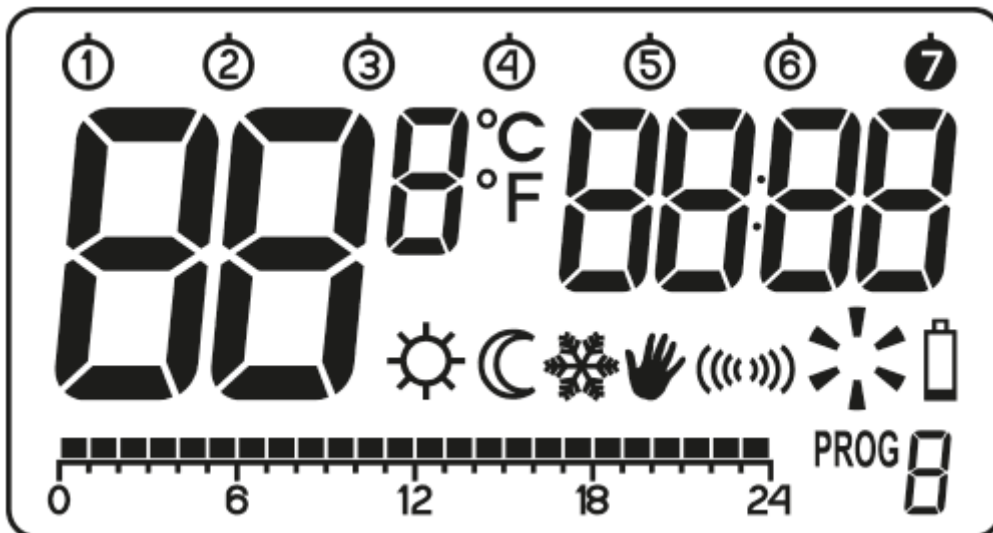

After a while, AURATON Libra DS will automatically switch to the time setting mode. A flashing item on

the screen means that the device is currently in the edit mode. Turn the knob to the left or right to set the required hour and confirm using the  button.



Turn the knob to the left or right to set the correct value on the minute segment and confirm using the  button.



A flashing symbol of the day of the week appears in the upper left corner. Turn the knob to the left or right to set the day and confirm the selection using the  button.

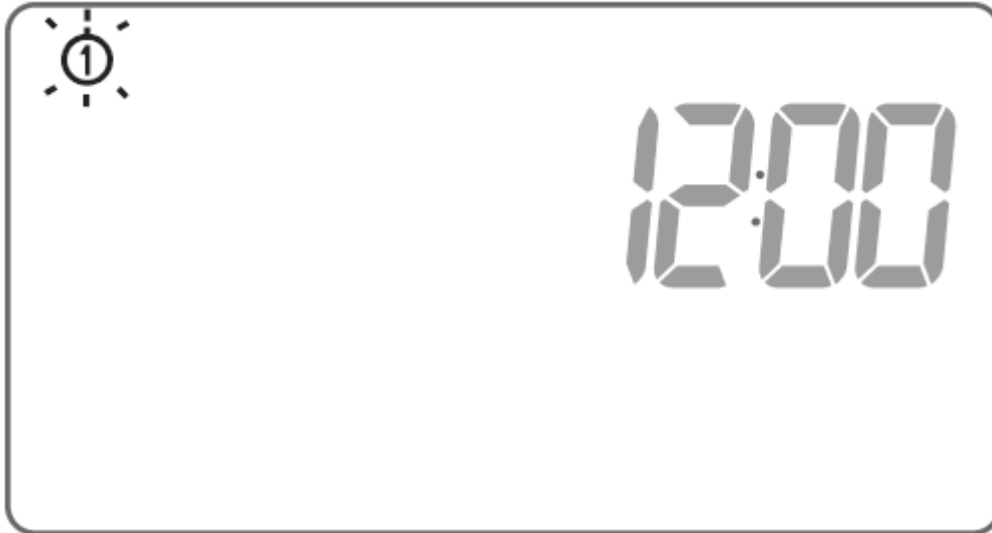

**IMPORTANT:**

If no button is pressed for 60 seconds in the initial edit mode, 12:00 o'clock and Monday, as the day of the week, will be set automatically.

**IMPORTANT:**

When programming any other functions, not pressing any button for 10 seconds is equivalent to using the  button.

## Setting the clock and day of the week

To set the clock:

Press the  button. The hour segment on the display will start flashing.

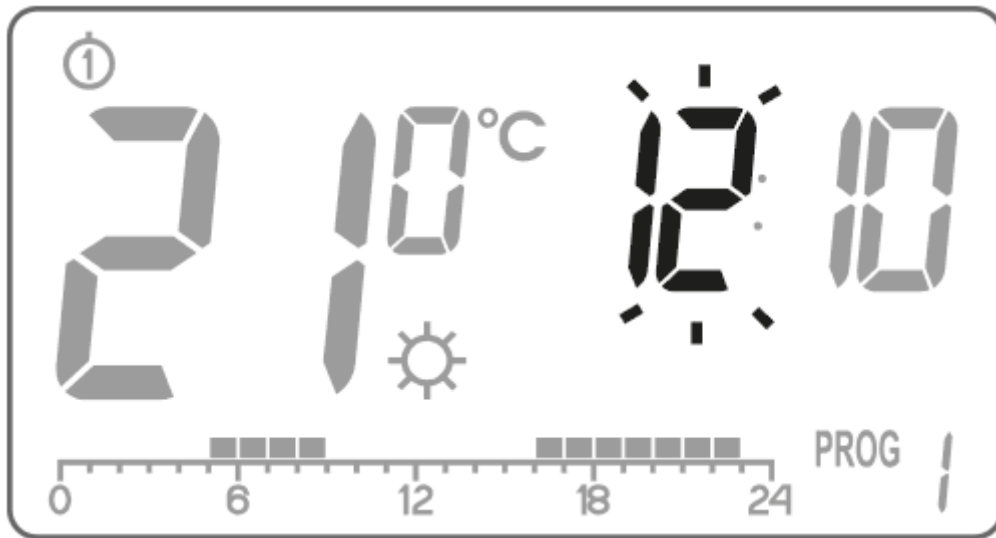

Turn the knob to the left or right to set the required hour and confirm with using the  button.

Turn the knob to the left or right to set the correct value on the minute segment and confirm using the  button.

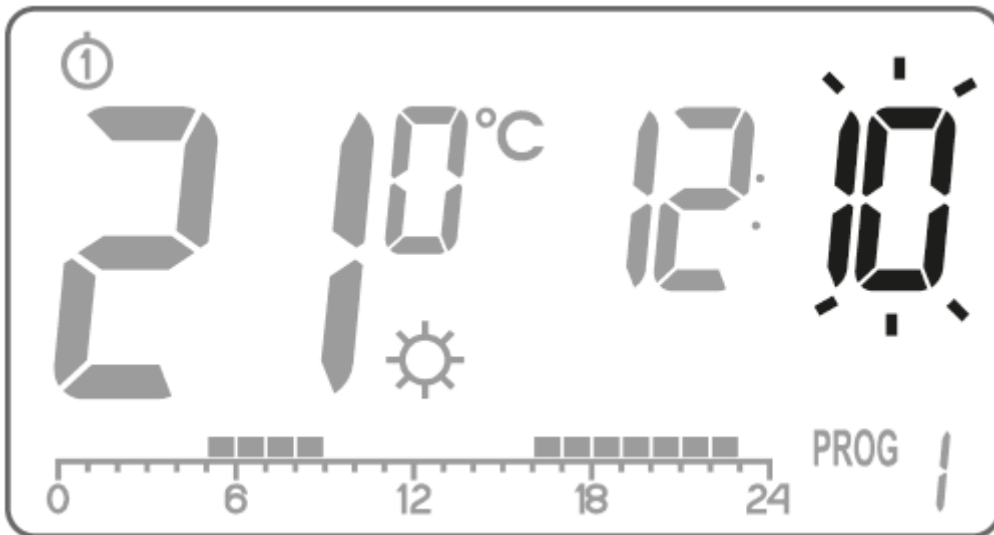

A flashing symbol of the day of the week appears in the upper left corner. Turn the knob to the left or right to set the day and confirm the selection using the **OK** button.

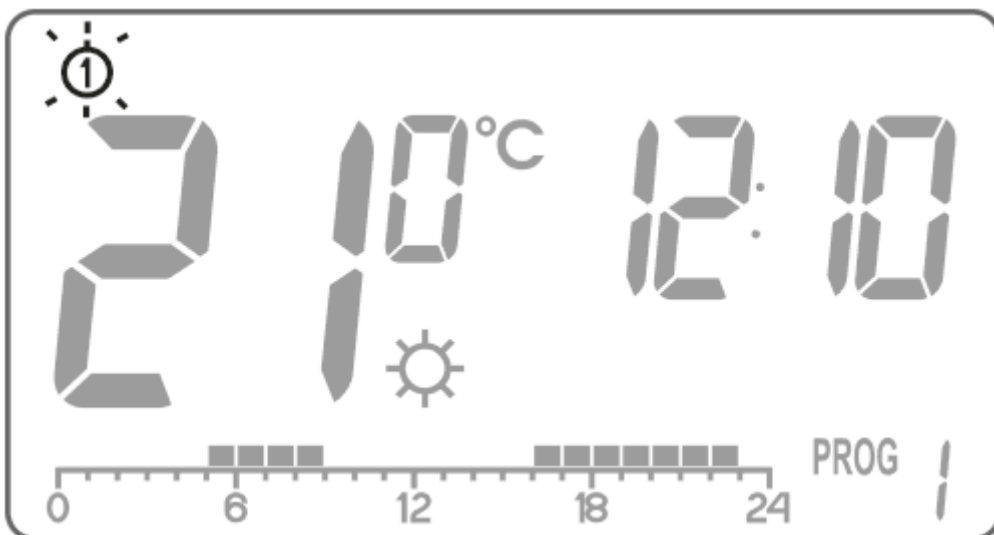

**IMPORTANT:**

You can also switch by pressing the  button.

## Default program setting

- **Monday - Friday:**

The heating device maintains the day temperature () from **05:00 to 8:00 A.M.** and from **3:00 to 11:00 P.M.**

- **Saturday - Sunday:**

The heating device maintains the day temperature () from **06:00 A.M. to 11:00 P.M.**

- **default temperature settings:**

 day temperature - 21,0°C



 night temperature - 19,0°C

 anti-freeze temperature - 7,0°C

 temperature of the external sensor - 40.0 °C (when an external sensor is connected)

## Programming day and night temperatures

AURATON Libra DS allows you to program 3 types of temperature:

- Day temperature () - from 5 to 30 °C
- Night temperature () - from 5 to 30 °C
- Temperature of the external sensor () - from 10 to 55 °C

To set one of the temperatures above:

1. Press the  button.





The display will show the currently set temperature with one of the two symbols:

 - **day temperature;**

 - **night temperature;**

 - **temperature of the external sensor** (when an external sensor is connected).



3. Turn the knob to the left or right to set the desired temperature value.
4. Pressing the  button will switch the edit mode between the day and night temperatures (, ).
5. After setting the temperatures, confirm using the  button.

**IMPORTANT:**

The night temperature setting can be equal to or lower than the day temperature. It is impossible for the night temperature to be higher than the day temperature.



# Introduction to programming

## Timeline

The timeline on the LCD display is divided into 24 sections. Each of them symbolizes 1 hour of the day. Black rectangles above the timeline mean that the day temperature has been programmed for specific hours, and that there is no night temperature.

Example:

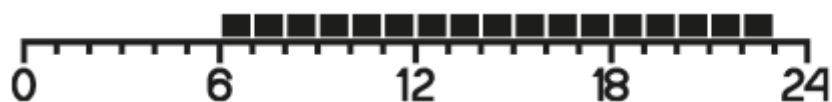

The figure above shows that from 6.00 A.M. to 11.00 P.M. Auraton Libra DS will control the heating device in such a way that the room temperature will be day temperature (☀). AURATON Libra DS will switch to night temperature from 11.00 P.M. to 6.00 A.M. (🌙).

## Factory programs

In order for AURATON Libra DS to know when to turn on the day and night temperatures, you should be set to an appropriate program for each day of the week. For this purpose, you can use one of the three factory programs (from 0 to 2):

### Program no. 0 - anti-freezing ❄️

Unmodifiable factory program. Designed for all-day anti-freezing temperature setting.

### Program no. 1 - weekly

Unmodifiable factory program. Sets day temperature from 5:00 to 8:00 A.M. and from 3:00 to 11:00 P.M.

### Program no. 2 - weekend

Unmodifiable factory program. Sets day temperature from 6:00 A.M. to 11:00 P.M.

### Programs no. 3, 4, ..., 8 - user-defined programs



Programs from 3 to 8 are user-defined programs. They can be freely modified and adapted to specific requirements.

## Programming

### Weekly programming

To program AURATON Libra DS, set the day temperature intervals for individual days of the week. At other time, night temperature will be set.

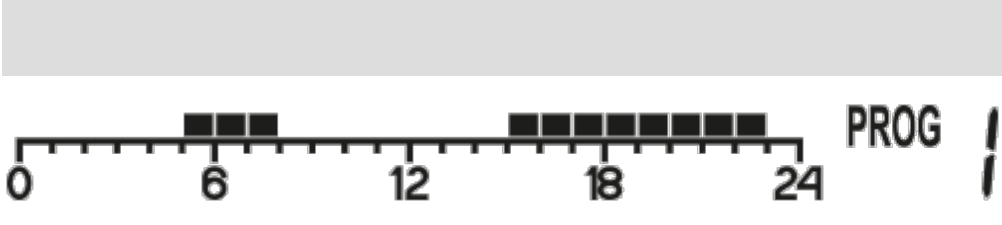
*Sample AURATON Libra DS setting from Monday to Sunday. Outside the intervals programmed, the night temperature will be set.*

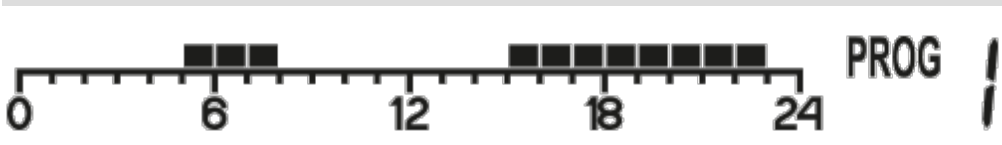
Day	Day temperature	
Monday	5:00 - 8:00 A.M.; 3:00 - 11:00 P.M.	
Tuesday	5:00 - 8:00 A.M.; 3:00 - 11:00 P.M.	
Wednesday	5:00 - 8:00 A.M.; 3:00 - 11:00 P.M.	

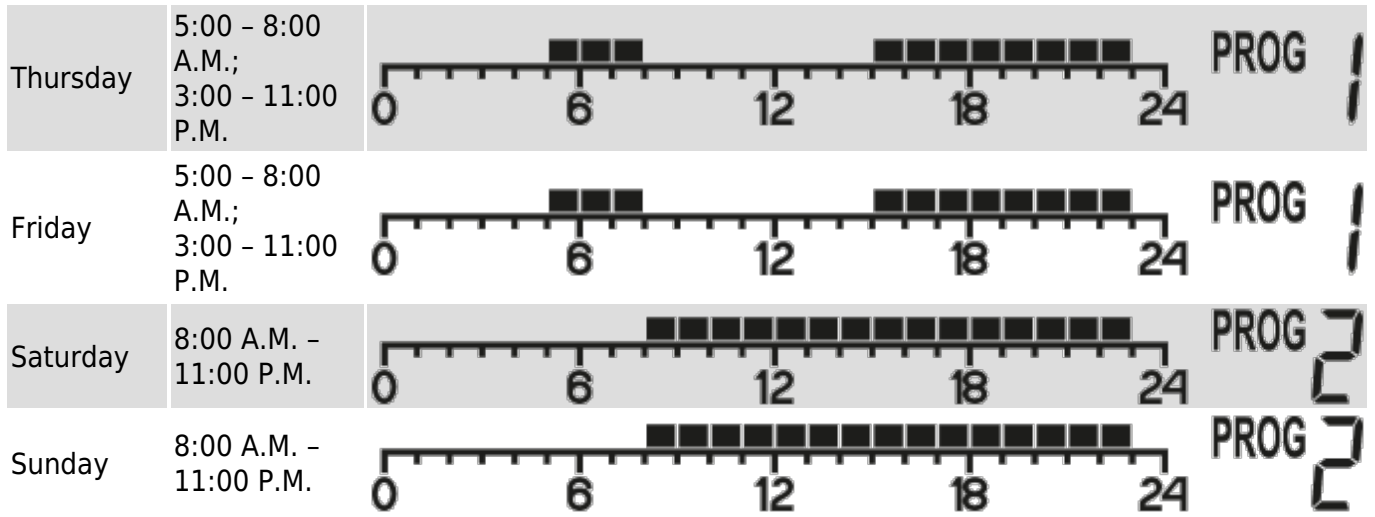

## Program selection

To set the program:

Press the **PROG** key. Program number segment will start blinking.

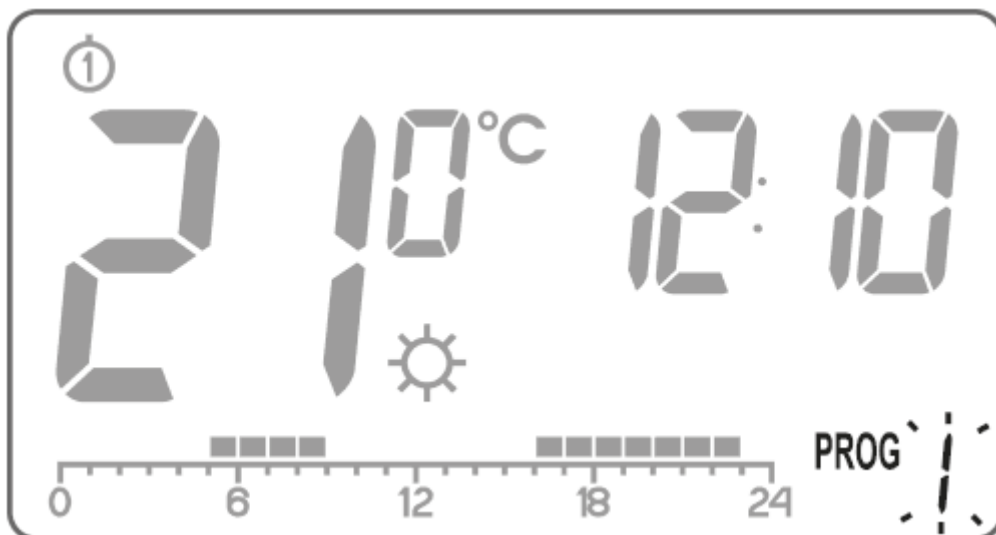

Press the  key as many times as required to set the day of the week for the program.

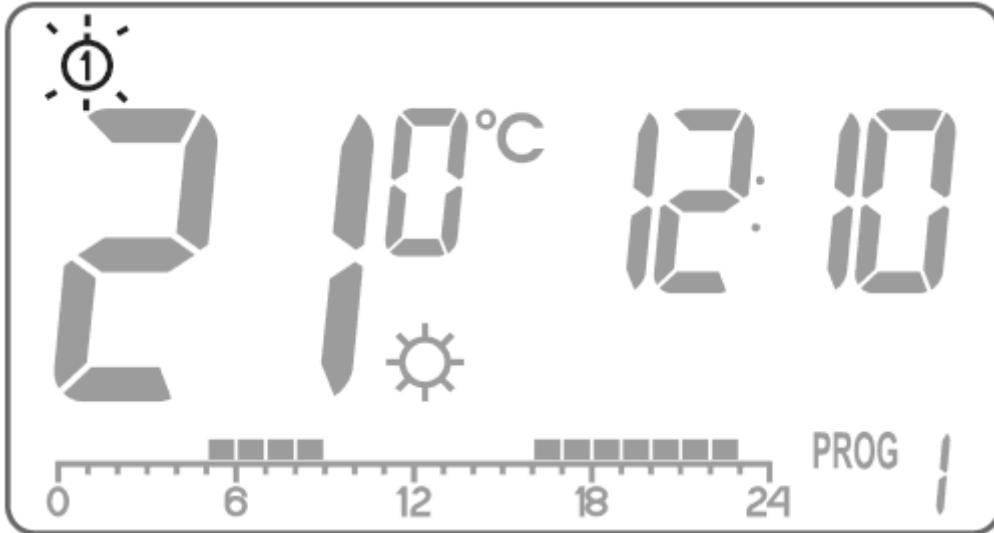

Press the  key several times and select the program number requested. Programs **0-2** are factory-set, programs **3-8** can be edited.

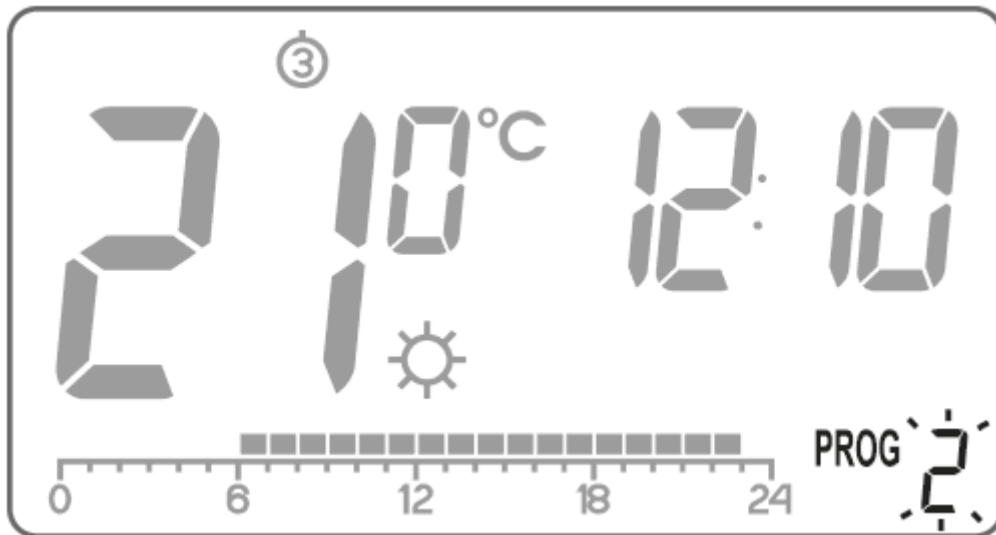



4. Confirm selection pressing the **OK** key.
5. Repeat the procedure for the following days of the week.

## **Modifying user-defined programs**

To set the program:

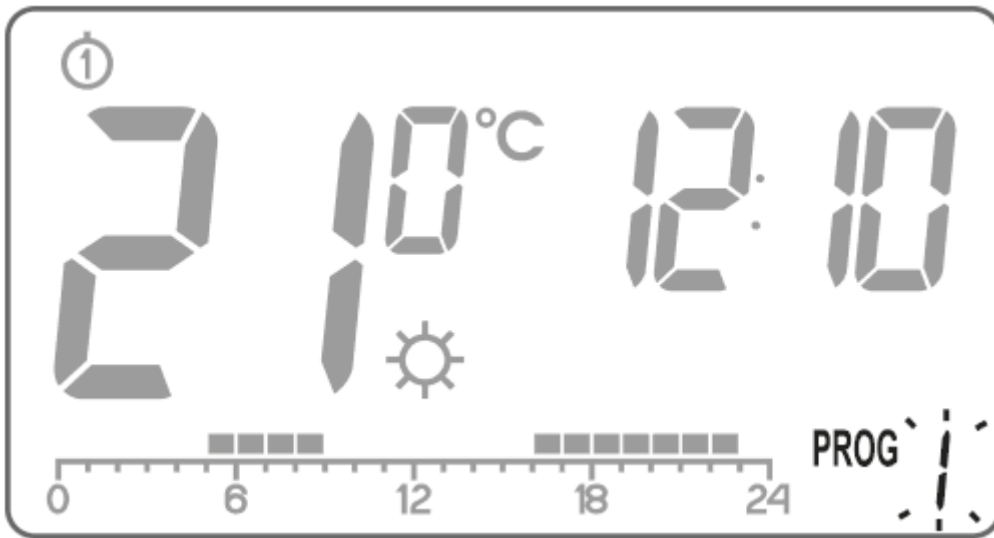
Press the **PROG** key. Program number segment will start blinking.



Press the  key as many times as required to set the day of the week for the program.

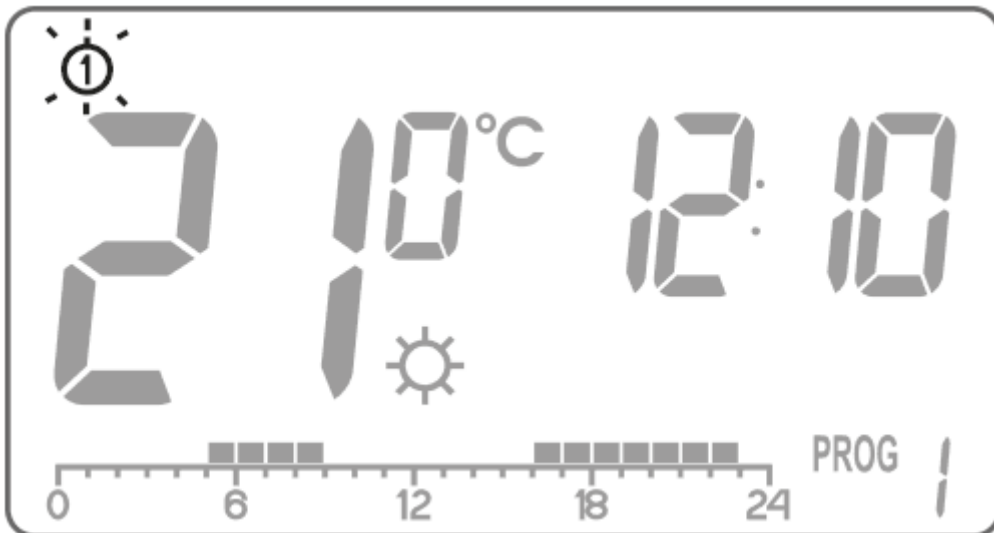

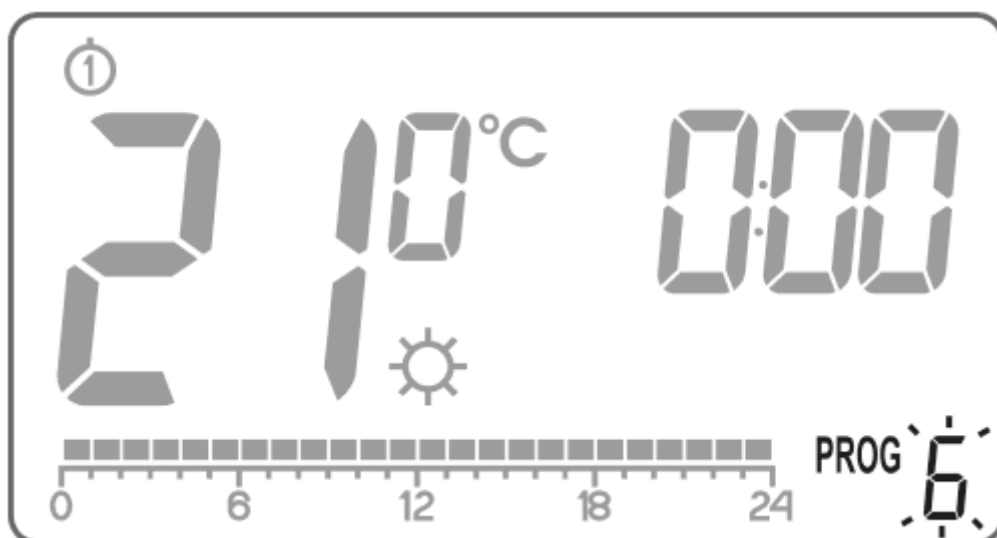

Press the **PROG** key several times to select the program number required. Programs **0-2** are factoryset, programs **3-8** can be edited.

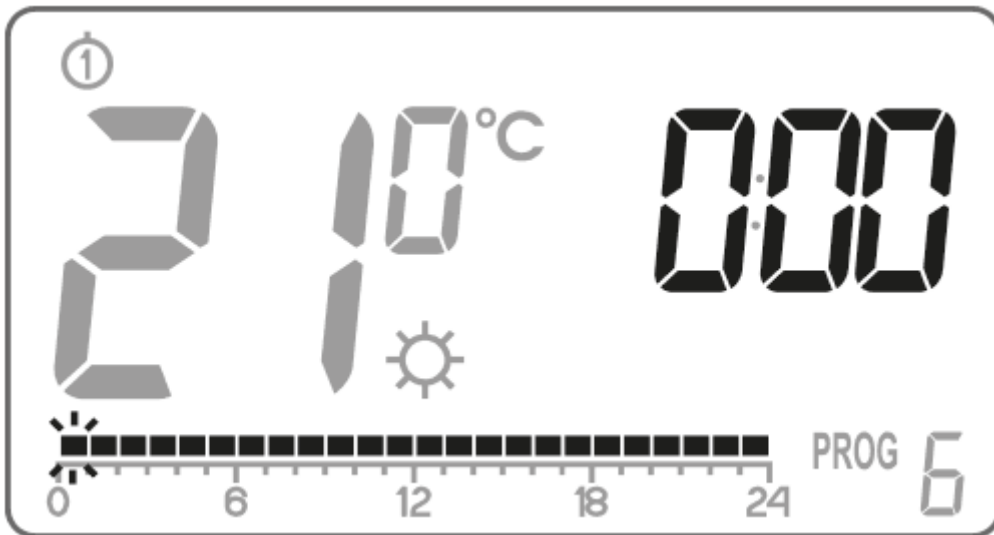

All (24) black rectangles will appear on the timeline. Each of them symbolises 1 hour. A visible rectangle indicates day temperature set for the given time. If no rectangle is displayed, night temperature is set.

Blinking rectangle indicates the point of the timeline which is modified.



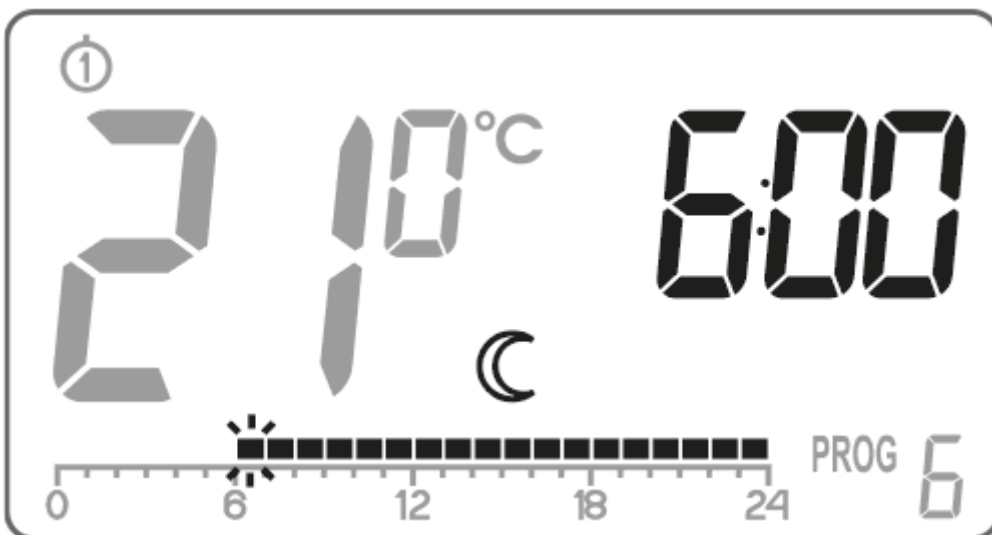

Press the  key to select day (rectangle on) or night temperature (no rectangle). Then, select the time interval for the temperature selected with the knob.



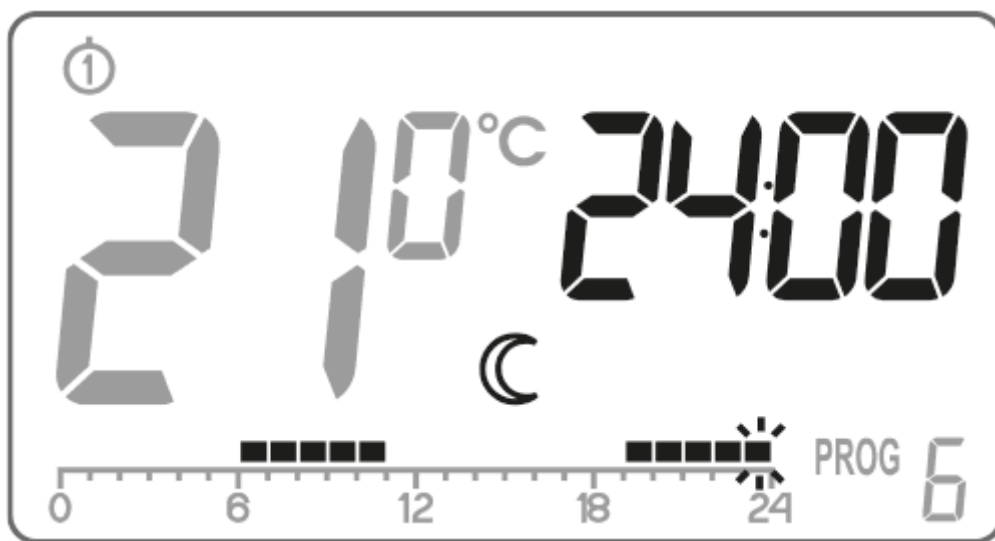

By pressing the  key and selecting time interval the entire program is modified.



7. Confirm selection with the  key.

**NOTE:**



**Any modified program for a specific day can also be selected and implemented during another day of the week.**



## Manual control



### Option 1:



If, for some reason, you want to stop the current program at a given moment and extend the day or night temperature, you can do it manually, but for not longer than 24 hours. To do this you should:



Hold the  button for 3 seconds. Then, using the knob, select the number of hours of manual operation (24 hours at the most) and confirm the setting using the  button.

AURATON Libra DS will wait until you choose one of the two temperatures which it should maintain (day or night). The change is made by using the  button or the knob. Confirm the selection using the  button.





### Option 2:

If you want to suspend the execution of a given program, e.g. due to a party lasting longer than expected, but AURATON Libra DS has already started lowering the temperature for the night (the  symbol has appeared on the display), you should:

Press the  button, the display will show the symbols of a  and the . The day temperature will then be maintained until the next temperature change carried out by the program.

To withdraw the above-mentioned action press the  button. The  symbol will disappear from the display.

Similarly, if the program is using the day temperature but you want it to implement the night temperature immediately, you should:

Press the  button. The display will show the symbols of a  and the . The night temperature will then be maintained until the next temperature change carried out by the program. To withdraw the above-mentioned action press the  button. The  symbol will disappear from the display.

## Anti-freezing temperature



In the event of being away for a long time, it is possible to turn on the anti-freezing temperature mode. It allows you to avoid the unpleasant consequences of water freezing in the heating system by automatically setting the temperature to 7°C. To set the anti-freezing program, simply select **program 0** for the desired day of the week.

## Resetting AURATON Libra DS

To perform a **reset**, remove the battery and wait until the data on the display disappears.

## Master reset of AURATON Libra DS

**MASTER RESET** is performed by pressing and holding the  button and at the same time installing the batteries. This causes AURATON Libra DS to return to its factory settings.

### **IMPORTANT:**

**All user-defined programs will be removed!**

## Configuration settings

Configuration settings are set one after another:

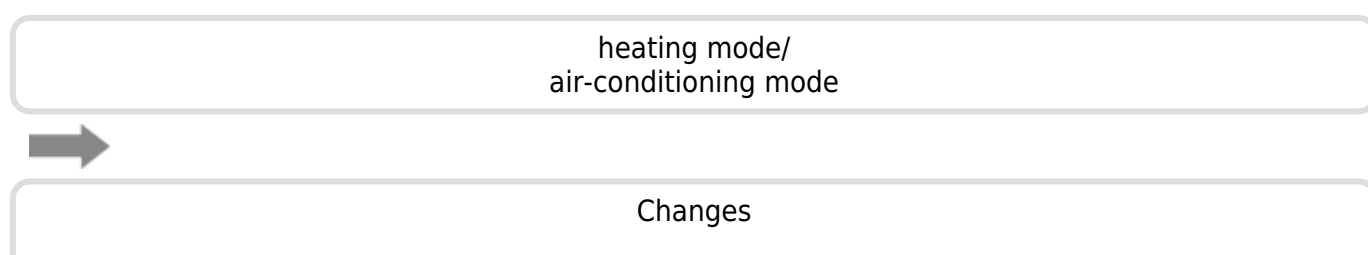

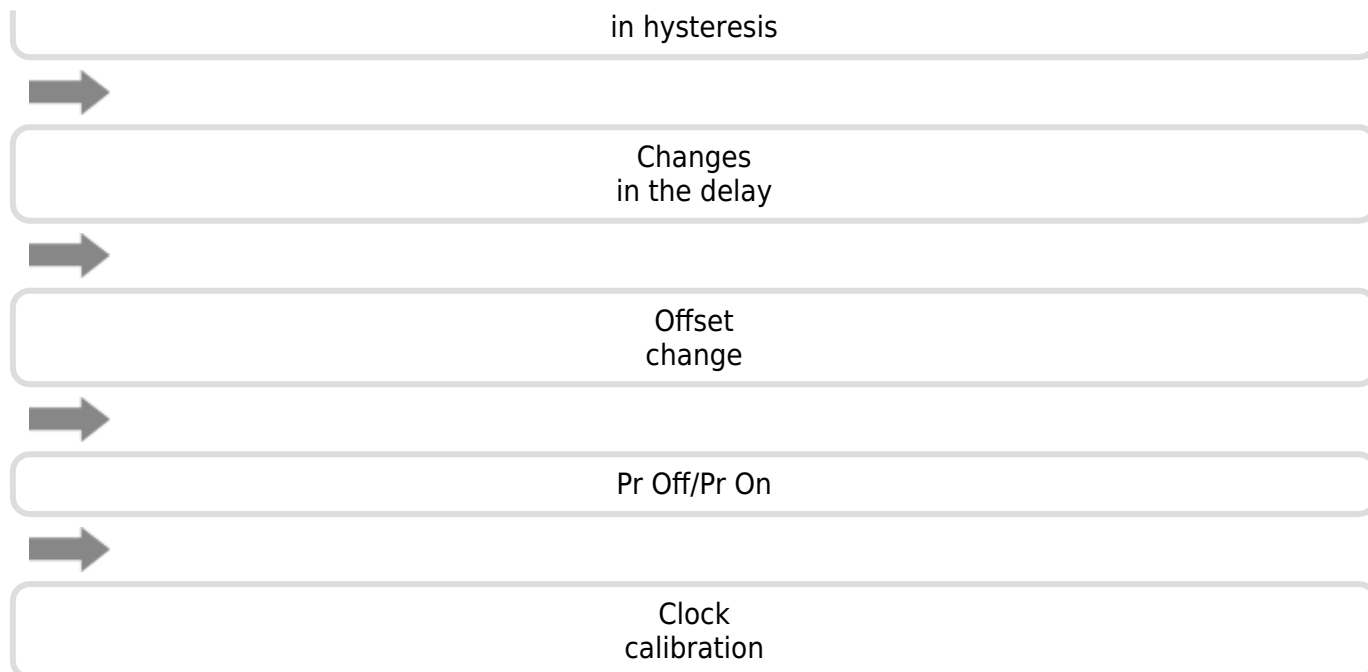

To enter the edit mode of the configuration settings, hold the **PROG** and **OK** buttons simultaneously for 3 seconds until the settings menu is displayed.

## Heating mode/air-conditioning mode

AURATON Libra DS can work in two modes:



**Heating mode** (preset) – set it if you want AURATON Libra DS to cooperate with heating devices.



**Air-conditioning mode** – set it if you want AURATON Libra DS to cooperate with air-conditioning devices.

Turn the knob to the left or right to set the required mode. Confirm your choice by pressing the **OK** button. AURATON Libra DS will proceed to change the next parameter.

## Changes in hysteresis

Hysteresis is supposed to prevent too frequent activation of the actuator due to small temperature fluctuations.

For example, in the case of **HI 2** hysteresis, when the temperature is set to 20 °C, the boiler will be switched on at 19.8 °C, and switched off at 20.2 °C. In the case of **HI 4** hysteresis, when the temperature is set to 20 °C, the boiler will be switched on at 19.6 °C, and switched off at 20.4 °C.

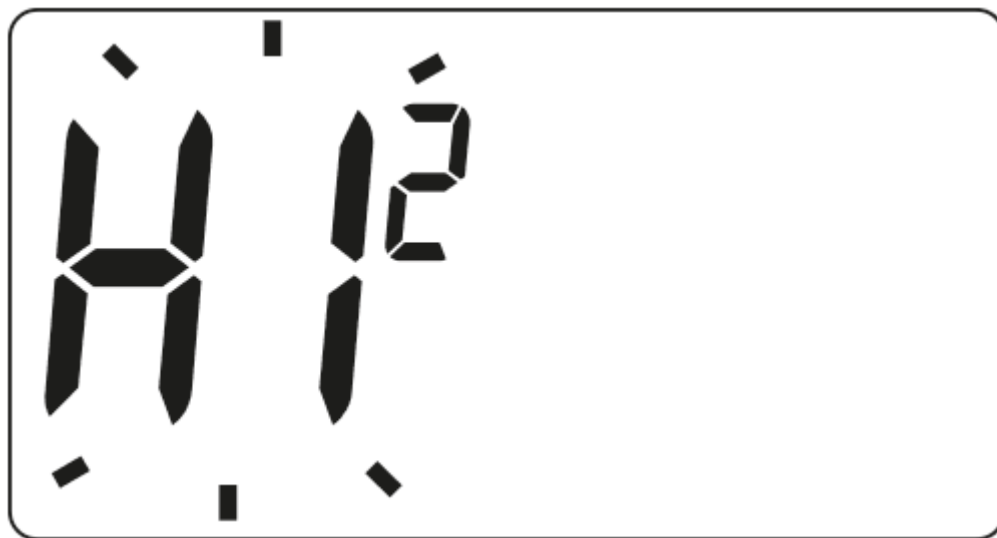

The hysteresis change mode is signaled by a flashing HI. Turn the knob to the left or right to set the desired hysteresis.

**HI 2** -  $\pm 0,2$  °C (preset),

**HI 4** -  $\pm 0,4$  °C,

**HI P** - PWM operating mode (see chapter "PWM operating mode").

Confirm your choice by pressing the  button. AURATON Libra DS will proceed to change the next parameter.

## Changes in the delay

The delay prevents too frequent activation of the actuator, e.g. due to temporary drafts (caused by opening the window, etc.).

The delay change mode is signaled by a flashing **90:SE**. By turning the knob left or right, we set the delay.

**90:SE** - delay of 90 s (preset),

**0:SE** - no delay

Confirm your choice by pressing the  button. AURATON Libra DS will proceed to change the next parameter.



## Offset change

Offset allows you to calibrate temperature indications with a tolerance of  $\pm 3$  °C. AURATON Libra DS may for example show that the temperature in the room is 23 °C, while a regular room thermometer next to it may show 24 °C. Changing the offset by +1 degree, will make AURATON Libra DS show the

same temperature as the room thermometer.

The offset change mode is signaled by a flashing OFFS. By turning the knob to the left or right, you can set the desired value in the range from -3.0 to 3.0 (preset - 0.0). Confirm your choice by pressing the

 button. AURATON Libra DS will return to the normal operating mode.



**IMPORTANT:**

If no button is pressed for 10 seconds while changing the configuration settings, AURATON Libra DS will return to the normal operating mode.

**IMPORTANT:**

Pressing any function button for the first time always turns on the backlight, and then the function of a specific button.

## Pr Off/Pr On

AURATON Libra DS has the function of emergency relay operation. In the event of too low battery voltage (indicator visible on the display), the user may decide to turn the relay off or on permanently.

In the AURATON Libra DS menu, you can select **Pr OFF** - relay permanently turned off or **Pr ON** - relay permanently turned on.

AURATON Libra DS will store these settings until new batteries are installed (low battery voltage indicator fades out).

If the external sensor is disconnected or damaged, two dashes will be displayed in place of temperature, and AURATON Libra DS will automatically switch to the anti-freeze mode.

In this case, install a new external sensor or reset AURATON Libra DS by removing the battery for a few minutes, which will cause AURATON Libra DS to switch to working with the internal sensor.

## Clock calibration

This function is used to correct the clock indications in case of any deviations. If the clock is working incorrectly within a week, the extent of incorrect clock indications should be determined. This value should be entered in AURATON Libra DS in the form of seconds.

### Example 1:

After a week of operation, AURATON Libra DS shows time accelerated by 1 minute and 20 seconds ( $60 + 20 = 80$ ). In this case you should slow down the clock by setting C -80.

### Example 2:

After a week of operation, the clock in AURATON Libra DS is 2 minutes slow ( $2 \times 60 = 120$ ). In this case you should speed up the clock by setting C 120.

### **IMPORTANT:**

**The number of seconds should be determined after one week of operation of AURATON Libra DS for the clock calibration function to work correctly (7 days = the number of seconds to be added or subtracted, maximum 294 seconds).**

### **IMPORTANT:**



**If no button is pressed for 10 seconds while changing the configuration settings, AURATON Libra DS will return to the normal operating mode.**

## PWM operating mode

(Pulse-Width Modulation)

By changing the hysteresis settings (chapter “Configuration settings”), you can turn on the PWM operating mode. In this mode, AURATON Libra DS cyclically turns on the heating device in order to minimize temperature fluctuations. AURATON Libra DS checks temperature rise times and temperature drop times.

Knowing these values makes AURATON Libra DS turn on and off the heating device in appropriate cycles to maintain the temperature to the set value as close as possible.

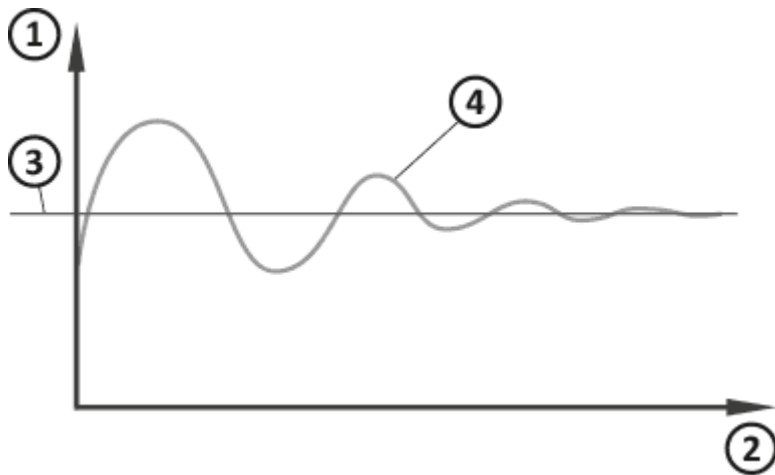

1. Temperature
2. Time
3. Set temperature
4. Room temperature

### **IMPORTANT:**

**AURATON Libra DS can turn on the heating device despite the fact that the temperature in the room is higher than the set temperature in the PWM mode. This is caused by the PWM algorithm aiming at maintaining the set temperature and anticipating the behavior of the thermal system.**

## **External temperature sensor**

### **AURATON Libra DS with an additional external temperature sensor**

AURATON Libra DS equipped with an additional socket allows you to connect an external temperature sensor (2.5 m included). In order for the external sensor to be detected, connect it and install the batteries that came with the thermostat. After activating the AURATON Libra DS with an additional sensor, you can set the maximum temperature of the external sensor in the range from 10 to 55°C. To check the temperature of the external sensor measured by AURATON Libra DS, briefly press the

**OK** button, and measured value will appear and blink for 5 seconds.

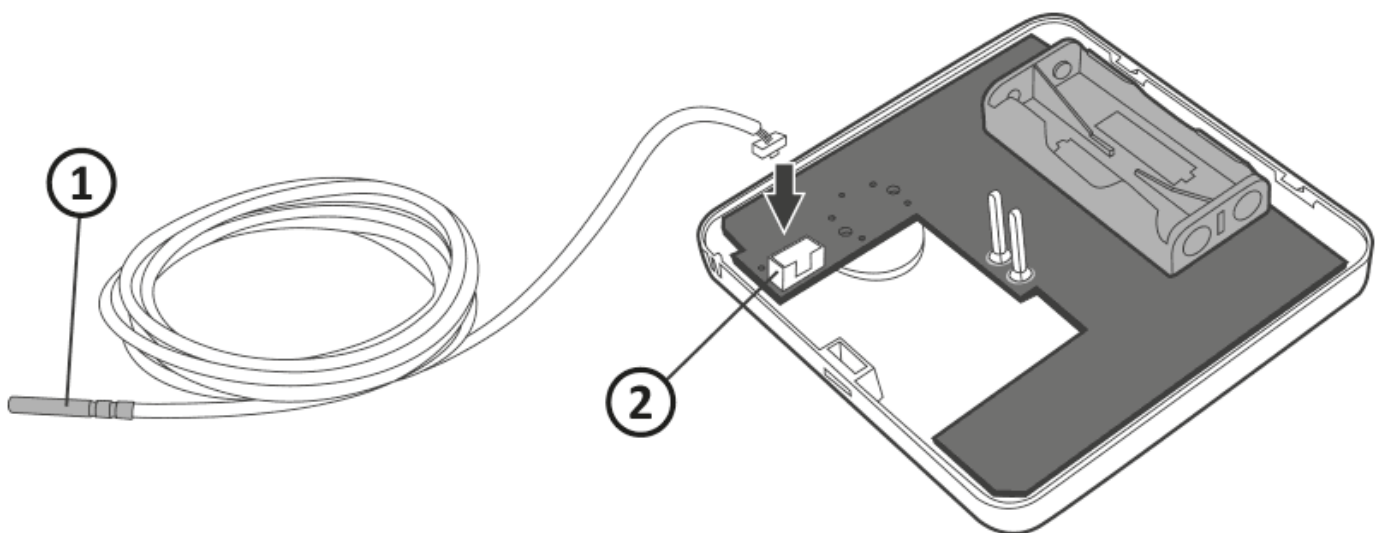

With an additional external sensor connected, AURATON Libra DS will maintain the temperature according to the air temperature (internal sensor), and the heating will be switched on until the temperature is reached by one of the sensors.

A situation may arise whereby the heating is turned off because the temperature of the external sensor has been reached despite the air temperature (internal sensor) not having been reached.





1. External temperature sensor
2. Connection block

If the external sensor is disconnected or damaged, AURATON Libra DS switches to safe mode (dashes are displayed in place of temperature) resulting in the relay and, consequently, the controlled device to be turned off. To exit the safe mode, reconnect the external temperature sensor or restart

AURATON Libra DS by pressing and holding the  and  buttons simultaneously.

Once this procedure is completed, AURATON Libra DS will again display the temperature from the internal sensor.

## Additional remarks

- At least 30 seconds must elapse between switching the relay off and on again.
- AURATON Libra DS enables you to turn on or off the control functions at any time (e.g. after a heating season) by briefly holding down (for about 5 seconds) the  button (AURATON Libra DS will only show the current time and room temperature - no "timeline").
- Pressing any function button for the first time always turns on the backlight, and then the function of a specific button. When using the knob, each step keeps the backlight on.
- When programming any function, not pressing any button for 10 seconds is equivalent to pressing the  button.

## The AURATON Libra DS connection schematics

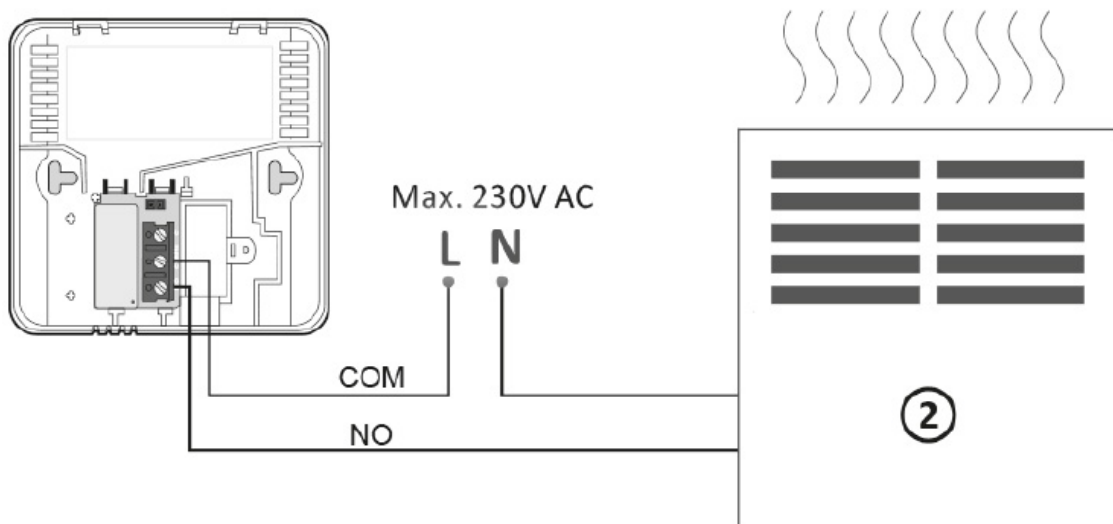
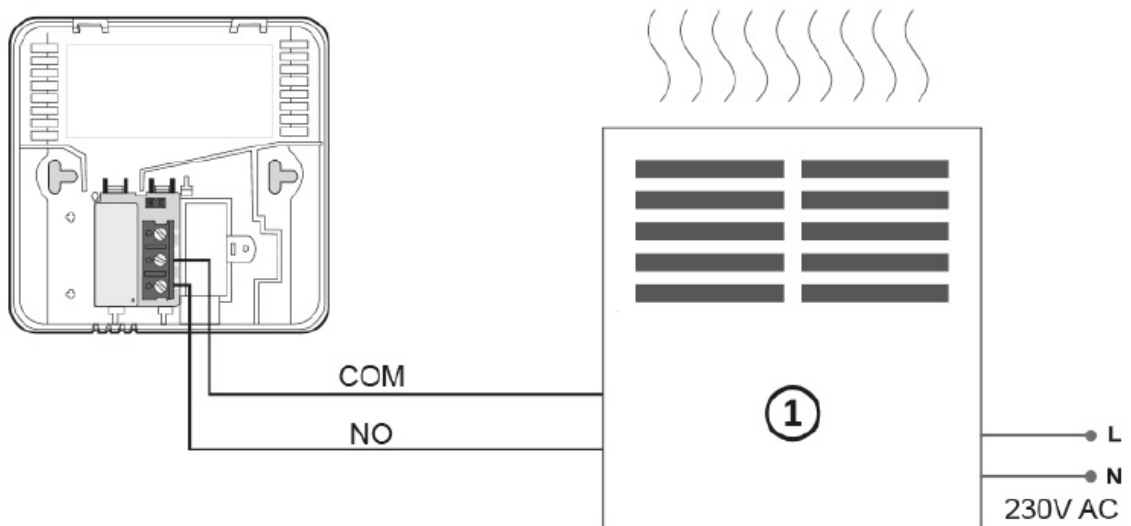

1. Heating device *e.g. a gas furnace*
2. Electric heating device (MAX 230 V AC, 16 A)

## Cleaning and maintenance

- The outside part the device should be cleaned with a dry cloth. Do not use solvents (such as

benzene, thinner or alcohol).

- Do not touch the device when your hands are wet. It may cause electric shock or serious damage to the device.
- Do not expose the device to excessive smoke or dust.
- Do not touch the screen with a sharp object.
- Keep the device away from liquids or moisture.

## Technical specifications

Power supply:	2 x AAA (2 x 1.5 V), alkaline
Working temperature range:	0 - 45 °C
Signalling the working status:	LCD
Number of temperature levels:	2
Anti-freeze temperature:	7 °C
Temperature control range with the external sensor:	10 - 55 °C
Temperature measurement range:	5 - 30 °C
Hysteresis:	±0.2 °C / ±0.4 °C / PWM
Relay load capacity:	Max. 250 V AC, max. 16 A
Working cycles:	Weekly programmable
Level of security:	IP20
Dimensions [mm]:	90 x 90 x 36

## Disposing of the devices

The devices are marked with the crossed-out wheeled bin. According to European Directive 2012/19/EU and the Waste Electrical and Electronic Equipment Act, this kind of marking indicates that the equipment, after its operational life must not be disposed of together with other waste from households.

**The user shall return it to a collection point for electrical and electronic waste.**



Hereby, LARS Andrzej Szymanski declares that the radio equipment type AURATON Libra DS is in compliance with Directive 2014/53/EU and 2011/65/EU. The full text of the EU declaration of conformity is available below in the download area.

---

**Contact and address of the manufacturer:**

LARS, ul. Świerkowa 14  
64-320 Niepruszewo  
www.auraton.pl

---

## Download

- [User manual](#)
- [Declaration of conformity](#)