

AURATON

S14

www.auraton.pl



User manual

CE

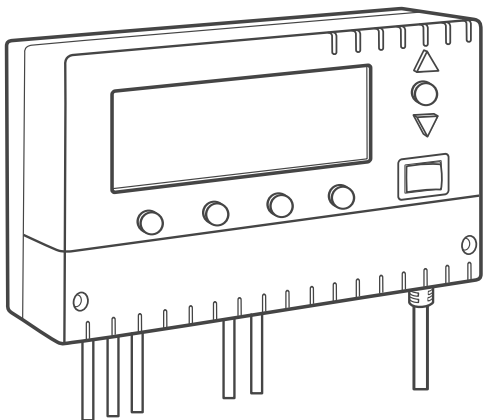

AURATON S14

AURATON S14 is a modern processor-based controller intended for work with central heating (CH) and hot domestic water (HDW) circulating pumps. The controller may work with a boiler stove fireplace in a CH system and with a forced draft coal or fine coal fired CH stove.

1 Description of the display

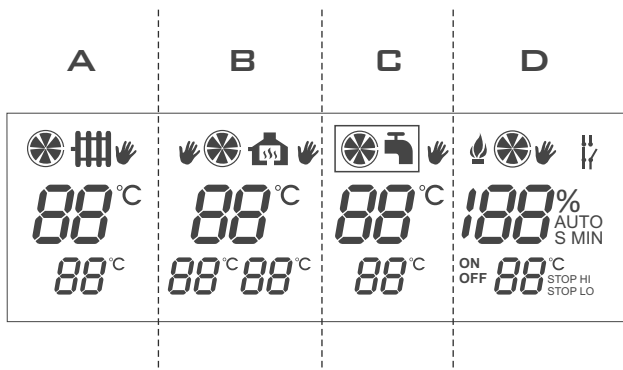

The display of the **AURATON S14** controller is divided into four parts. Each part corresponds to a separate device supported by the controller:

- Part A:** Control of the central heating (CH) pump,
- Part B:** Control of the central heating (CH) pump, the automatically reset actuator, or the second central heating pump (in the fireplace circuit),
- Part C:** Control of the hot domestic water (HDW) circulating pump,
- Part D:** Control of the fan (blower).

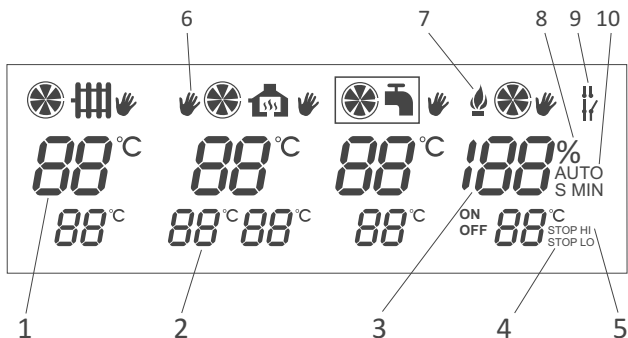

1. Temperature measured by individual sensors,
2. User's setting,
3. Counted operation time of the fan and the duration of the interval between the blow-throughs,
4. Indicator of extinguished fire in the furnace,
5. Indicator of emergency shutdown of the fan,
6. Indicator of manual activation of the device,
7. Indicator of ignition,
8. Indicator of fan power percentage value,
9. Indicator of forced operation (of the CH pump),
10. Indicator of sustained fire in the furnace.

2 Description of buttons and cable terminals

NOTE: In order to access the cable terminals, remove the front cover.

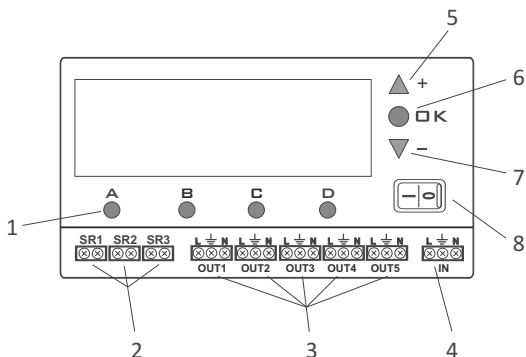

- Buttons "A, B, C, D" for configuration of individual settings,
- Terminals for connecting temperature sensors (SR1 through SR3),
- Terminals for connecting actuators (OUT1 through OUT5),
- Terminals for connecting the power supply,
- "+" (plus) button - higher value,
- "OK" button - approval,
- "-" (minus) button - lower value,
- Main power supply switch.

General comments

- Before connecting the cables to the controller, remove the protective plugs by cutting them off.
- Only one sensor is provided (with an approx. 2.5 m long cable). If an expanded functionality of the controller is required, additional temperature sensors must be bought (option). If the length of the cable is inadequate, a sensor with an approx. 15 m long cable can be purchased.

3 Description of the controller working in a CH circuit (part A of the display)

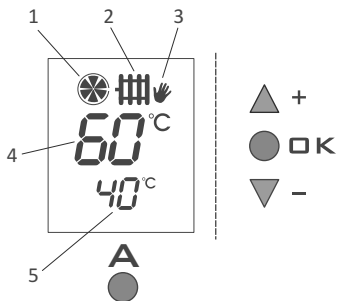

1. CH pump operation indicator,
2. CH pump's sensor indicator,
3. Manual mode operation indicator,
4. Current temperature on the CH sensor (SR1),
5. Set temperature indicator.

The controller-pump assembly forces the water to circulate in a CH system with a coal-fired boiler or a gas boiler without a system controlling the operation of the pump. The controller's sensor measures the temperature of the water on the supply side of the CH system.

In a CH system with a coal-fired boiler, the controller switches off the circulation pump after the flame in the boiler is extinguished. Pumping of water is not recommended when the flame is extinguished because the air draft into the chimney causes faster cooling of the water in the boiler faster than in the radiators. The optimum temperature can be set on the controller's scale (most often approx. 40°C).

In a CH system with a gas boiler, the temperature must be lower than the temperature set on the CH boiler's thermostat. If the temperature is set above the dew point, it prevents condensation in the boiler during the heating of the water in the CH system.

The controller also has the **GUARD** functions which prevents the stalling process in the rotor of the pump when it is not in use. Also, a built in processor starts the pump for 30 seconds after the heating season is over.

In order for the system to work after the heating season, the controller must be switched on.

3.1. Installation

3.1.1. Mounting the controller

The controller must be mounted on a wall or another support using two screws (the concrete anchors with screws are delivered with the controller). The cables extending from the controller must be fixed to the wall with cable clips.

3.1.2. Mounting the sensor

Before installing the cables, remove the protective plugs by cutting them off. In the controller, connect the temperature sensor to the **SR1** terminals. Then install the sensor on an uncovered outlet pipe connected to the CH boiler (as close to the boiler as possible).

NOTE: If a coal-fired boiler and a gas-fired boiler work in the same CH system, the sensor should be installed in a location where the two outlets merge and must be insulated.

3.1.3. Connecting the power supply cable of the pump

In the controller, the pump's cable must be connected to the **OUT1** terminal. In the pump, connect the green or yellow-green wire (grounding or protective zero) to the "⏏" terminal and connect the blue wire to the "N" terminal. Connect the brown wire to the "L" terminal.

3.1.4. Connection check

Check if the wire is connected properly and fix the lid of the pump motor's compression box with screws.

3.1.5. Connecting the controller



After the wires are secured to prevent accidental ripping, connect the power supply cable to a 230V AC/50 Hz power outlet with a grounding pin.

 **NOTE: The ambient temperature in the place where the controller is installed must not exceed 40°C.**

 **NOTE: The wires and cables may be connected only when the power supply is cut off.**

3.2. Operation of the controller

3.2.1. Switching the controller on

Put the switch  in the "I" position. After the controller is switched on, all segments of the display are lit for about 2 seconds and the software version is displayed. Then the  symbol, the current sensor temperature (4), and the set temperature (5) are shown on the display.

3.2.2. Description of the display

The top part of the display (4) shows the current temperature of the sensor while the bottom part (5) shows the set temperature. Movement of the blades on the indicator (1) indicates operation of the CH pump.

3.2.3. Changing the temperature

Press the "A" button under the temperature setting. The digits begin to blink and indicate the value of the current setting. Using the "+" (increase) or "-" (decrease) button, set the desired temperature. After the temperature value is set, approve it (within 10 seconds) by pressing the "OK" button. Otherwise, the changed value will not be saved and the controller will return to the previous setting.

3.2.4. Changing the hysteresis

Press the "A" button under the temperature setting. The digits begin to blink and indicate the value of the current setting. Display the hysteresis setting (HI) by pressing the "A" button again. Using the "+" or "-" button, set the required hysteresis value in the range of 2°C to 10°C (with a 2°C increment). After the value is set, approve it (within 10 seconds) by pressing the "OK". Otherwise, the changed setting will not be saved and the controller will return to the previous setting.

Example: If the temperature setting is 40°C and the hysteresis is 4°C, the pump will start at 42°C and will stop at 38°C.

3.2.5. Changing the forced pump operation mode

Press the "A" button under the temperature setting. The digits begin to blink and indicate the value of the current setting. Display the hysteresis setting (HI) by pressing the "A" button again. After you press the "A" button one more time, the value of 85°C will be displayed in the temperature section and on the right side of the display the symbol of forced pump operation (⏸). Za pomocą przycisku „+” lub „-” will be shown. Using the "+" or "-" button, select a setting where, after the temperature exceeds 85°C, the pump is in continuous operation (⏸) or shuts down (⏹).

After the pump operation mode is set, approve it (within 10 seconds) by pressing the "OK" button. Otherwise, the changed setting will not be saved and the controller will return to the previous setting.

3.2.6. Automatic operation

After this operation mode is set, the controller starts and stops the pump depending on the set temperature. In the CH system, the pump is started when the temperature in the location of the sensor exceeds the set value and stopped when the temperature drops below the value set in the controller, taking into account the hysteresis.

3.2.7. Manual mode - continuous operation

In order to manually switch on the circulating pump (regardless of the current temperature at the **SR1** (CH) sensor), press the "A" button and hold it pressed for 3 seconds.

The display will show the hand symbol "☞" (3). If you wish to switch off the pump's manual operation, press the "A" button again and hold it pressed for 3 seconds.

NOTE: When only the SR1 sensor is connected, the remaining functions of the controller are inactive, i.e. there is no indication of operation of CH pumps in the fire place circuit and of the control of the pump in the HDW circuit.

3.3. Diagram of connection of the controller with the pump at the CH boiler

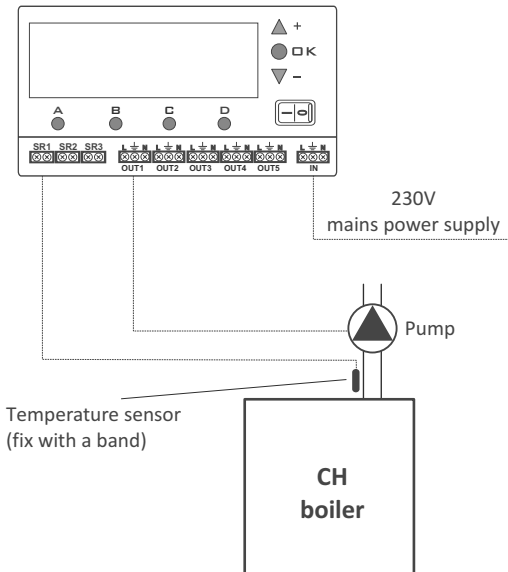

4 Description of a controller working with a CH pump and an automatically reset actuator, or with a second CH pump - a fireplace boiler stove circuit (part B of the display)

1. Current temperature on the CH sensor (SR2)
2. Indicator of the set CH temperature in the fireplace circuit,
3. Indicator of the set temperature of the automatically reset actuator or the second CH pump,
4. Indicator of manual activation of the CH pump,
5. CH pump operation indicator,
6. Indicator of operation of a tee valve or the second CH pump,
7. Indicator of manual activation of a tee valve or the second CH pump.

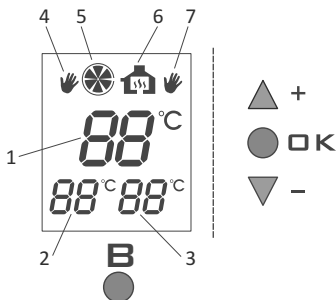

AURATON S14 in a circuit with a boiler stove fireplace uses two control outputs:

- one for the water pump in the fireplace circuit;
- one for an actuated valve or the second pump, which is required for proper cooperation between the boiler stove fireplace with the CH circuit.

After the power supply is switched on, temperature in the water jacket of the boiler stove fireplace is measured (with the digital sensor); the temperature signal can be divided into two independent channels.

Depending on the temperature of water in the fireplace circuit, the controller automatically starts or stops the CH pump of the fireplace and starts the valve or the second pump.

The **AURATON S14** controller also has the **GUARD** functions which prevents the stalling process in the rotor of the pump when it is not in use. After the heating season, **AURATON S14** automatically starts the pump for 30 seconds every 14 days.

In order for the system to work after the heating season, the controller must be switched on at all times.

4.1. Installation

4.1.1. Mounting the controller

The controller must be mounted on a wall or another support using two screws (the concrete anchors with screws are delivered with the controller). The cables extending from the controller must be fixed to the wall with cable clips.

4.1.2. Mounting the sensor

Before installing the cables, remove the protective plugs by cutting them off. In the controller, connect the temperature sensor to the **SR2** terminals. Then install the sensor on the outside of the fireplace's water jacket or on an uncovered outlet pipe connected to the CH boiler (as close to the boiler as possible). The sensor must not be immersed in liquids or installed at the fireplace smoke outlets.

4.1.3. Connecting the power supply cable of the CH pump

The CH pump must be connected to the **OUT2 (L, \perp , N)** terminals. In the pump, connect the green or yellow-green wire (grounding or protective zero) to the " \perp " terminal, the blue wire - to the "N" terminal, and the brown wire - to the "L" terminal.

4.1.4. Connecting the power supply cable to the valve (or the second CH pump)

In the controller, the valve's cable must be connected to the **OUT3** terminal (L, \perp , N). In the valve, connect the green or yellow-green wire (grounding or protective zero) to the terminal (grounding symbol), the blue wire - to the "N" terminal, and the brown wire - to the "L" terminal.

4.1.5. Connecting the controller

After the wires are secured to prevent accidental ripping, connect the power supply cable on the side of the controller to the **IN (L, \perp , N)** terminals. Then connect the cable to a 230V AC/50 Hz power outlet with a grounding pin.



NOTE: The ambient temperature in the place where the controller is installed must not exceed 40 °C.



NOTE: The wires and cables may be connected only when the power supply is cut off.

4.2. Operation of the controller

4.2.1. Switching the controller on

Set the power supply switch  in the "I" position. After power is switched on, all segments of the display light up. Then the controller indicates the current temperature of measured by the sensor.

4.2.2. Settings range

- Temperature (from 0°C to 99°C) is measured by the **SR2** sensor,
- The CH pump is controlled using the **OUT2** output,
- The automatically reset actuator and the second CH pump is controlled using the **OUT3** output,
- The settings range for the CH pump and the automatically reset actuator (or the second CH pump) is equal to 10°C to 85°C, and the hysteresis (the temperature difference between the start and the stop settings) is adjustable in the range of 2°C to 10°C.

4.2.3. Changing the temperature

Press the "**B**" button for a short time. When the CH set temperature indicator (left) in the fireplace circuit starts blinking, use the "+" or "-" button to set the desired temperature.

Press the "**B**" button again. When the CH set temperature indicator (right) of the valve or the second CH pump in the fireplace circuit starts blinking, use the "+" or "-" button to set the desired temperature. After the value is set, approve it (within 10 seconds) by pressing the "**OK**" button. Otherwise, the changed value will not be saved and the controller will return to the previous setting.

4.2.4. Changing the hysteresis

Press the "**B**" button under the temperature setting. The digits begin to blink and indicate the value of the current setting (left indicator). When the "**B**" button is pressed again, the right temperature indicator starts blinking. Press the "**B**" button in order to edit the value of hysteresis (**HI**), in the range of 2°C to 10°C, for the CH pumps (left indicator). Then use the "+" or "-" button to set the required hysteresis value. When the "**B**" button is pressed again, the hysteresis (**HI**) is set, in the range of 2°C to 10°C, for the valve or the second CH pump (right indicator). Then use the "+" or "-" button to set the required hysteresis value. After the value is set, approve it (within 10 seconds) by pressing the "**OK**" button.

Otherwise, the changed setting will not be saved and the controller will return to the previous setting.

Example: If the temperature setting is 40°C and the hysteresis is 4°C, the pump will start at 42°C and will stop at 38°C.

4.2.5. Changing the forced pump operation mode

Press the "B" button under the temperature setting. The digits begin to blink and indicate the value of the current setting (left indicator). When the "B" button is pressed again, the right temperature indicator starts blinking. Press the "B" button again in order to edit the hysteresis (HI) value of the left indicator. Press the "B" one more time in order to set the hysteresis (HI) value of the right indicator.

After you press the "B" button one more time, the value of 85°C will be displayed in the temperature section and on the right side of the display the symbol of forced pump operation (⏸) will be shown. The "+" or "-" button can be used to make the pump work in a continuous manner (⏸) or stop (⏹) after the temperature of 85°C is exceeded. Also, the "+" or "-" button can be used to set the maximum value, equal to 55°C, which, when exceeded, will cause the CH pump to stop (e.g. in the case of floor heating).

The operation of the valve or the second CH pump can be set in the same manner. After the operation mode is set, it must be confirmed (within 10 seconds) by pressing the "OK" button. Otherwise, the changed setting will not be saved and the controller will return to the previous setting.

4.2.6. Automatic operation

The controller starts or stops the pump and the valve depending on the set temperature value. In the CH system, the pump and the valve are started when the temperature in the location of the sensor exceeds the set value and stopped when the temperature drops below the value set in the controller, taking into account the hysteresis.

4.2.7. Tryb ręczny - praca ciągła

Step 1 – In order to manually switch on the CH pump in the fireplace circuit (regardless of the current temperature at the SR2 sensor), press the "B" button for 3 seconds. The display will show the hand symbol "👤" on the left side of the pictogram indicating operation of the CH pump in the fireplace circuit.

Step 2 – If you press the "B" button again for 3 seconds, the manual mode "👤" will be activated for the tee valve (or the second CH pump) "👤" (hand symbol on the right side).

Step 3 – If you press the "B" button one more time for 3 seconds, the manual mode "👤" will be activated for the CH pump (left side).

Step 4 – If you press the "B" button yet again for 3 seconds, the manual mode "👤" will be activated for the automatically reset valve (or the second CH pump) in the fireplace circuit (right side).

4.3. Wiring diagram

An example wiring diagram. This is a simplified diagram that does not contain all the elements necessary for proper operation of the system.

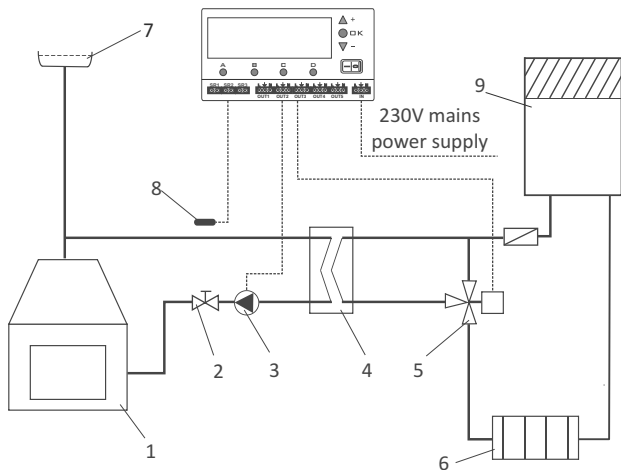

- | | |
|----------------------------------|------------------------|
| 1. Boiler stove fireplace, | 6. Radiator, |
| 2. Cut-off valve, | 7. Compression vessel, |
| 3. Pump, | 8. Temperature sensor, |
| 4. Exchanger , | 9. CH boiler. |
| 5. Automatically reset actuator, | |

NOTE: When only the SR2 sensor is connected, the remaining functions of the controller are inactive, i.e. there is no indication of operation of CH pump and of the control of the pump in the HDW circuit, and the blower is not controlled.

5 Description of the controller working with a hot domestic water (HDW) pump (part C of the display)

1. Current temperature on the HDW sensor (SR3),
2. Temperature setting in the HDW circuit,
3. Indicator (frame) of HDW priority over CH,
4. Indicator of operation of the pump in the HDW circuit,
5. Indicator of manual activation of the pump in the HDW circuit.

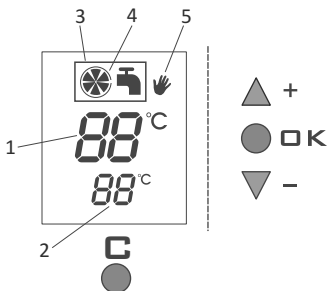

The **AURATON S14** electronic pump controller is also intended for automatic control of the circulation pump (depending on the temperature) in the hot domestic water (HDW) circuit.

The controller maintains constant temperature of water in a tank or in the HDW circuit.

The controller has priority functions which prevent cooling down water in the HDW tank.

5.1. Operation with the HDW over CH priority switched on

If the HDW over CH priority function is switched on, then the pump in the HDW circuit depends only on the setting and on the temperature measured by the **SR3** sensor installed in the tank.

5.1.1. Settings range

Temperature (from 0°C to 99°C) is measured by the **SR3** sensor. The HDW pump is controlled using the **OUT4** output. The settings range for the HDW pump is equal to 10°C to 85°C, and the hysteresis (the temperature difference between the start and the stop settings) is adjustable in the range of 2°C to 10°C.

5.1.2. Programming of the HDW functions

When the "C" button is pressed, the value of 50 °C (factory setting) starts blinking. Use the "+" or "-" button to set the desired temperature.

Once the desired temperature value is set, it must be confirmed (do not forget to do so) within 10 seconds by pressing the "OK" button. Otherwise, the changed value will not be saved and the controller will return to the previous setting.

After the new value has been saved, the controller leaves the settings status and switches to normal operation (the temperature setting stops blinking). The controller starts the HDW pump (OUT4) if the temperature measured by the SR3 sensor exceeds the set temperature value by the hysteresis value and stops the pump when the temperature drops below the hysteresis value.

5.1.3. Manual mode - continuous operation

In order to manually switch on the circulating pump (regardless of the current temperature at the SR3 (HDW) sensor), press the "C" button and hold it for 3 seconds. The display will show the "👉". If you wish to switch off the HDW pump's manual operation, press the "C" button again and hold it pressed for 3 seconds.

NOTE: If the temperature measured by the sensor (SR3) exceeds 85 °C, the HDW pump will be switched off in order to prevent excessive heating of hot water in the tank.

5.2. Operation with the HDW over CH priority switched on

If the HDW over CH priority function is switched on, then activation of the pump in the HDW circuit depends not only on the setting and on the temperature measured by the **SR3** sensor, which is installed in the HDW tank, but also on the temperature measured by the **SR1** (CH) sensor.

If the HDW over CH priority function is switched on and if a situation occurs where two HDW pumps and a CH pump should be in operation at the same time (provided that the **SR1** (CH) temperature sensor is connected and that the power supply cable of the CH pump (**OUT1**) is connected), then the operation of the HDW pump has a priority.

The way it works is that the HDW pump is started first and is in operation until the desired temperature is reached and then the CH pump is started. What the HDW over CH priority function also does is that if the temperature measured by the **SR1** (CH) sensor is lower than the temperature measured by the **SR3** (HDW) sensor, then the HDW pump does not start. This prevents cooling down water in the HDW tank.

5.2.1. Manual mode - continuous operation

In order to manually switch on the circulating pump (regardless of the current temperature at the **SR3** (HDW) sensor), press the "**C**" button and hold it for 3 seconds.

5.3. Installation

5.3.1. Mounting the controller

The controller must be mounted on a wall or another support using two screws (the concrete anchors with screws are delivered with the controller). The cables extending from the controller must be fixed to the wall with cable clips.

5.3.2. Mounting the sensor

On the controller side, the temperature sensor must be connected to the **SR3** terminals and then installed in the hot domestic water tank. The sensor must not be immersed in liquids or installed at the fireplace smoke outlets. The maximum measured temperature value is 99 °C.

5.3.3. Connecting the power supply cable of the HDW pump

In the controller, the HDW pump's cable must be connected to the **OUT4** terminal (**L**, \perp , **N**). In the pump, connect the green or yellow-green wire (grounding or protective zero) to the " \perp " terminal. Connect the blue wire to the "**N**" terminal and the brown wire to the "**L**" terminal.

5.3.4. Connecting the controller

After the wires are secured to prevent accidental ripping, connect the power supply cable on the side of the controller to the **IN** terminals (**L**, $\frac{\perp}{\perp}$, **N**). Then connect the cable to a 230V/50 Hz power outlet with a grounding pin.



NOTE: The ambient temperature in the place where the controller is installed must not exceed 40°C.



NOTE: The wires and cables may be connected only when the power supply is cut off.

5.4. Operation of the controller

5.4.1. Switching the controller on

Set the power supply switch  in the "I" position. After power is switched on, all segments of the display light up for about 2 seconds. Then the controller indicates the current temperature of measured by the sensor.

5.4.2. Changing the temperature



Press the "□" button. When the set temperature indicator in the HDW circuit starts blinking, use the "+" or "-" button to set the desired temperature. Once the desired temperature value is set, it must be confirmed (do not forget to do so) within 10 seconds by pressing the "□K" button. Otherwise, the changed value will not be saved and the controller will return to the previous setting.

5.4.3. Changing the hysteresis

Press the "□" button under the temperature setting. The digits begin to blink and indicate the value of the current setting. Display the hysteresis setting (**HI**) by pressing the "□" button again. Using the "+" or "-" button, set the required hysteresis value in the range of 2°C to 10°C (with a 2 °C increment). After the value is set, approve it (within 10 seconds) by pressing the "□K" button. Otherwise, the changed setting will not be saved and the controller will return to the previous setting.

Example: If the temperature setting is 40°C and the hysteresis is 4°C, the pump will start at 38°C and will stop at 42°C.

5.4.4. Switching on the priority function

Press the "□" button under the temperature setting. The digits begin to blink and indicate the value of the current temperature setting. Display the hysteresis setting (**HI**) by pressing the "□" button again. Then press the "□" button again to display the HDW pump operation indicator (). Using the "+" and "-" buttons, switch on ( - frame) or switch off ( - no frame) the priority function.

5.4.5. Switching on the emergency heat takeoff function

NOTE:

As a default setting, the emergency heat takeoff function is switched off. Be very careful when using this function. The maximum temperature of water in the tank is 85 °C, which may lead to the risk of scalding of people, in particular small children!

Press the "C" button under the temperature setting. The digits begin to blink and indicate the value of the current temperature setting. Display the hysteresis setting (HI) by pressing the "C" button again. Then press the "C" button again to display the HDW pump operation indicator (🔧).

When the "C" button is pressed once again (this enables switching the emergency heat takeoff function on or off), lines are displayed (and blink) in the "A" section and in the "C" section (the function is off). When the lines are displayed, changes can be made using the "+" or the "-" button. After the function is switched on, section "A" displays the value of 85°C, which means that above this temperature value (measured by the SR1 sensor), the CH pump will be started (in the "A" section). On the other hand, section "C" (setting value) displays the value of 85°C, which means that the tank will collect heat but only to the value of 85°C (SR3). Also, the forced operation indicator (the CH pump is switched on) is displayed. After the value is set, approve it (within 10 seconds) by pressing the "OK" button. Otherwise, the changed setting will not be saved and the controller will return to the previous setting.

The emergency heat takeoff function is used in situations where the temperature in the system increases to dangerous levels above 85°C and enables quick takeoff of the heat by the heating system. In such situations, the HDW tank is used as a heat buffer. Also, the CH pump in the "A" section is used.

NOTE: The emergency heat takeoff function uses the CH pump in the "A" section only when the forced pump operation mode (⚡) is switched on in the "A" section.

5.5. Wiring diagram

5.5.1. HDW circuit

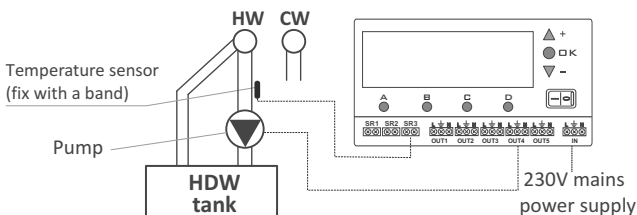

5.5.2. With the HDW tank

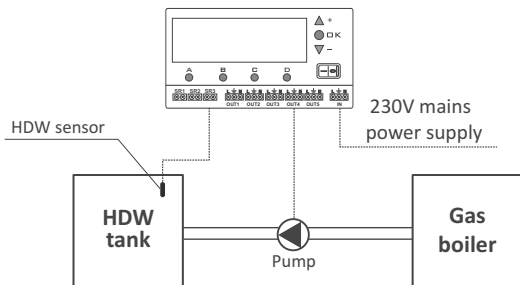

NOTE: When only the SR3 sensor is connected, the remaining functions of the controller are inactive, i.e. there is no indication of operation of CH pump (SR1) and of the control of the CH pump and the tee valve in the fireplace circuit, and the blower is not controlled.

6 Use of a fan (part D of the display)

1. Ignition indicator,
2. Fan operation indicator,
3. Manual fan activation indicator,
4. Fan power percentage value indicator,
5. AUTO function indicator,
6. Counting of operation time of the fan and the duration of the interval between the blow-throughs. "EE" signaling, hysteresis setting; fan power and start time setting,
7. Symbols indicating the fan operation settings (ON) and the interval between the blow-throughs (OFF),
8. Temperature setting above which the fan will be switched on and off periodically (according to the settings),
9. STOP HI function indicator,
10. STOP LO function indicator,
11. Set time unit (S - second, MIN - minute).

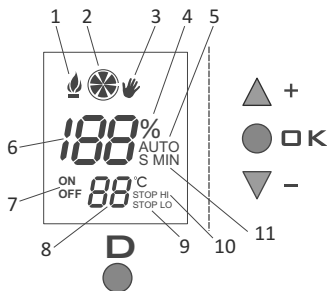

AURATON S14 is a modern processor-based controller intended for work also with forced-draught coal and fine coal fired boilers.

Depending on the temperature of water in the boiler, the controller automatically starts or stops the water pump in the CH circuit with a coal-fired boiler and the blower installed under the furnace.

The controller's digital sensor measures the temperature of the water in the boiler and controls the pump and the blower based on the measured values.

The **AURATON S14** controller also has the **GUARD** functions which prevents stalling the rotor of the pump when it is not in use.

6.1. Installation

6.1.1. Mounting the controller

The controller must be mounted on a wall or another support using two screws (the concrete anchors with screws are delivered with the controller). The cables extending from the controller must be fixed to the wall with cable clips.

6.1.2. Mounting the sensor

In the controller, connect the temperature sensor to the **SR1** terminals. Then install the sensor on the boiler in the designated place.

The sensor must not be immersed in liquids or installed at the boiler smoke outlets. The maximum measured temperature value is 99°C.

6.1.3. Connecting the power supply cable to the blower

In the controller, the blower's cable must be connected to the **OUT5** terminal (**L**, \perp , **N**). In the blower, connect the green or yellow-green wire (grounding or zero) to the " \perp " terminal, the blue wire - to the "**N**" terminal, and the brown wire - to the "**L**" terminal.

6.1.4. Connecting the controller

After the wires are secured to prevent accidental ripping, connect the power supply cable on the side of the controller to the **IN** terminals (**L**, \perp , **N**). Then connect the cable to a 230V/50 Hz power outlet with a grounding pin.



NOTE: The ambient temperature in the place where the controller is installed must not exceed 40 °C.



NOTE: The wires and cables may be connected only when the power supply is cut off.

6.2. Operation of the controller

6.2.1. Switching the controller on

Set the power supply switch  in the "I" position. After power is switched on, all segments of the display light up and the software version is shown for about 2 seconds. Then the controller indicates the current temperature of measured by the **SR1** sensor.

6.2.2. Settings range

- The settings range is between 10°C and 85°C.,
- The operation time and interval between blow-throughs settings are from 0 seconds to 99 minutes. ,
- The fan is controlled using the **OUT5** output and the set temperature refers to the temperature measured by the **SR1** sensor (CH),
- The range of the hysteresis settings is between 2°C and 10°C (with a 2°C increment).

6.2.3. Changing the temperature

Press the "D" button once for a short time. The set value --- °C (the fan is switched off as a default) starts blinking. Then use the "+" or "-" buttons to set the desired temperature value above which the fan will be switched on and off periodically.

Once the desired temperature value is set, it must be confirmed (do not forget to do so) within 10 seconds by pressing the "OK" button. Otherwise, the changed value will not be saved and the controller will return to the previous setting.

6.2.4. Changing the operation time and the time of periodic breaks in the fan's operation

Press the "D" button once. The fan temperature will start blinking. If you press the "D" button again within 10 seconds, the controller will switch to programming of the time of the fan's periodic operation (the blow-through - the default value is 10 seconds). Then use the "+" or "-" button to set the desired value (after 59 seconds, the time is automatically displayed in minutes).

If you press the "D" button one more time within 10 seconds, you will be able to set the time of the periodic break in the fan's operation (the time between the subsequent blow-throughs - the default value is 5 minutes).

Then use the "+" or "-" button to set the desired value (if you go below 1 minute, the time is automatically displayed in seconds). Once the desired value is set, it must be confirmed (do not forget to do so) within 10 seconds by pressing the "OK" button. Otherwise, the changed setting will not be saved and the controller will return to the previous setting.

AUTO operation mode

During normal operation, when the controller attempts to reach the temperature value set in the "D" section, the **AUTO** text is displayed. At that time, the fan is working at full power (programmed as a percentage) until the set value is reached. After the temperature is reached, the fan switches to periodic operation (with breaks between blow-throughs).

6.2.5. Furnace extinguishing function

If the temperature on the **SR1** sensor drops below the preset value (the factory setting is 30°C) for at least 30 minutes, then the fan is stopped definitively and the display shows the blinking text **STOP LO**. The fan leaves the definitive switch off state automatically when the temperature measured by the **SR1** sensor increases above 30 °C.

The definitive fan switch off temperature can be set in the range of 15 °C to 40°C. To do so, press the "D" button and display the fan temperature. If you press the "D" button again, the fan operation time and the break time settings will be displayed. By pressing the "D" button yet again (the shut-down temperature and the **STOP LO** text are displayed), you can set the definitive fan switch-off temperature.

Using the "+" (increase) and "-" (decrease) buttons, you can set the desired temperature value. Once the desired temperature value is set, it must be confirmed (saved) within 10 seconds by pressing the "OK" button.

Otherwise, the changed setting will not be saved and the controller will return to the previous setting.

6.2.6. Changing the hysteresis

To change the hysteresis value, press the "D" button and display the fan temperature. If you press the "D" button again, the fan operation time and the break time settings will be displayed. By pressing the "D" button yet again, you will display the definitive fan switch-off temperature and the **STOP LO** text. Press the "D" button one more time and use the "+" or "-" button to set the desired hysteresis value. Once the desired temperature value is set, it must be confirmed (saved) within 10 seconds by pressing the "OK" button. Otherwise, the changed setting will not be saved and the controller will return to the previous setting.

Example: Then the temperature setting is 40°C and the hysteresis setting is 4°C, the fan is permanently switched on when the temperature drops below 38°C and moves to periodic operation when the temperature reaches 42 C.

6.2.7. Setting the maximum fan power value

The controller has a function that enables fixing the maximum fan power as a percentage value. The fan power can be set in the range of 30% to 100% (where 100% is the maximum fan power value). In order to change the fan power, press the "D" button and display the fan temperature. If you press the "D" button again, the fan operation time and the break time settings will be displayed. By pressing the "D" button yet again, you will display the definitive fan switch-off temperature and the **STOP LO** text. Press the "D" button one more time and set the desired hysteresis value.

After you press the "D" button again, you can set the maximum fan power (the displayed factory-set value is 100%).

Use the "+" (increase) or "-" (decrease) buttons to set the desired value of fan power. Once the desired temperature value is set, it must be confirmed (saved) within 10 seconds by pressing the "OK" button. Otherwise, the changed setting will not be saved and the controller will return to the previous setting.

NOTE: Maximum fan power in the range of 30% to 100% means that the fan will also be in operation during ignition with the preset value of power.

6.2.8. Setting the fan's soft start time



AURATON S14 enables setting the time within which, after its start, the fan will reach its full power (the percentage value that has been set - see item 6.2.7. Setting the maximum fan power value). It is possible to set the fan's soft start time in the range of 0 seconds (start with the full set power) to 15 seconds, after which the fan reaches its full preset power. The value can be set using the "+" (increase) or "-" (decrease) buttons. Once the desired temperature value is set, it must be confirmed (saved) within 10 seconds by pressing the "OK" button.

Otherwise, the changed setting will not be saved and the controller will return to the previous setting.

6.2.9. Manual mode - continuous operation

In order to manually switch on the fan (regardless of the current temperature at the **SR1** sensor), press the "D" button for 3 seconds. The display will then show the "👤" sign next to the fan symbol. If you wish to switch off the fan's manual operation, press the "D" button again and hold it pressed for 3 seconds.

6.2.10. Automatic ignition function



The  symbol displayed in the "D" section means that the fan is switched on permanently with the maximum power (programmed as a percentage value) and that simultaneously the circulating pump in the "A" section is switched on. The symbol lights up when, after the control is switched on with the  switch, the water temperature measured by the **SR1** sensor is lower by at least a half of the hysteresis value than the value set in the "D" section. The display in the "D" section shows a countdown of the time (30 minutes) needed to ignite the fire in the boiler.

If the temperature shown in the "D" section (**SR1**) is not reached within 30 minutes, then the fan is switched off and the CH pump is unblocked at the same time in section "A" (a blinking ignition symbol).

The flame (ignition) symbol in the "D" section is switched off automatically when the boiler reaches a temperature that is higher than the temperature value set in the furnace extinguishing function (**STOP LO**); then the furnace switches to normal operation. It is also possible to switch off and then switch on again the controller using the  switch in order to start the ignition function.

6.2.11. Adding fuel to the furnace

During normal operation, fuel can be added, with the operation of the fan blocked, in two ways:

- Switch off the controller using the  switch. Add fuel and then switch on the controller and start the ignition function at the same time,
- The second method consists in implementing the fuel adding function by pressing and holding the "D" button for 5 seconds (after 3 seconds, the  symbol is displayed; if you hold the button for 2 more seconds, the fuel adding function becomes activated).

The "D" section of the display shows a 20-second countdown and then the controller returns to regular operation (before the fan is switched on, a sound warning will be emitted).

The fuel adding function can be switched off at any time by holding the "D" button for 5 seconds.

6.2.12. Emergency fan shutdown

If the temperature in the "D" section (**SR1** sensor) exceeds 90 °C, the fan is shut down (the display will show the **STOP HI** text) until the temperature drops below that value.

6.3. Explanation of the display's functions

LO the controller displays the "LO" text if the temperature measured by the SR1, SR2, and SR3 sensors drops below 0°C.

EE the controller displays the "EE" text if the temperature measured by the SR1, SR2, and SR3 sensors exceeds 99 °C

6.4. Diagram of the connection between the controller, the pump, and the boiler blower

NOTE: When only the SR1 sensor is connected, the remaining functions of the controller are inactive, i.e. there is no indication of operation of CH pumps in the fire place circuit and of the control of the pump in the HDW circuit.

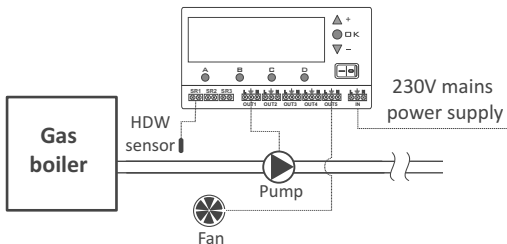

7 Operation of screen illumination

Each time any button is pressed, the display is illuminated for about 1 minute.

If the illumination needs to be switched on permanently, press and hold the "OK" button and the "+" button for about 3 seconds. The activation of the permanent illumination is confirmed with a sound signal.

The permanent illumination can be switched off by pressing the "OK" and "-" button simultaneously. The deactivation of the permanent illumination is confirmed with a sound signal.

NOTE:

The first time any function button is pressed, the illumination is switched on first (if the permanent illumination is switched off) and only then the button's function is activated. Any and all changes made using buttons are confirmed with sound signals.

8 RESET

In extreme situations (such as crashing of the controller), the RESET function can be used. The **RESET** button is located under the flap covering the outlet terminals.

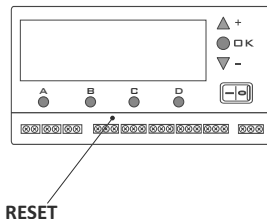

9 MASTER RESET

This function enables restoring the factory settings. In order to use it, press the "+" button, the "K" button, and the "-" button simultaneously for 5 seconds.

10 Technical data

A. Data pertaining to the controller working in a CH circuit

Temperature settings range:	10°C ÷ 85°C
Range of measured values:	0°C ÷ 99°C
Hysteresis (start/stop diff.)	from 2°C to 10°C
Supply voltage:	230V / 50Hz
Maximum load for output sum:	6A

B. Data pertaining to the controller working with a CH pump and a tee valve "Z" (or with a second CH pump in a fireplace boiler stove circuit)

Temperature settings range:	10°C ÷ 85°C
Range of measured values:	0°C ÷ 99°C
Hysteresis (start/stop diff.)	from 2°C to 10°C
Supply voltage:	230V / 50Hz
Maximum load for output sum:	6A

C. Data pertaining to the controller working with a hot domestic water (HDW) pump

Temperature settings range:	10°C ÷ 85°C
Range of measured values:	0°C ÷ 99°C
Hysteresis (start/stop diff.)	from 2°C to 10°C
Supply voltage:	230V / 50Hz
Maximum load for output sum:	6A

D. Data pertaining to the controller working with a fan

Temperature settings range:	10°C ÷ 85°C
Range of measured values:	0°C ÷ 99°C
Hysteresis (start/stop diff.)	from 2°C to 10°C
Supply voltage:	230V / 50Hz
Maximum load for output sum:	6A
NOTE: The maximum load in the "D" section is 1 A (230 W / AC switch)!	
Blow-through time and time of the interval between blow-throughs:	0 - 59 sec. and 1 - 99 min.

Cleaning and maintenance

- The outside of the controller must be cleaned with a clean cloth. Do not use solvents (such as benzene, thinners, or alcohol).
- Do not touch the device with wet hands. This can lead to electric shock or serious damage to the device.
- Do not expose the device to excessive impact of smoke or dust.
- Do not touch the display with sharp objects.
- Avoid contact of the device with liquids and moisture.

Disposing of the devices



The devices are marked with the crossed waste bin symbol. According to European Directive no. 2002/96/EU and the Act concerning used up electric and electronic equipment, such a marking indicates that this equipment may not be placed with other household generated waste.

The user is responsible for delivering the devices to a reception point for used-up electric and electronic equipment.



CE